









Electrical Safety

This equipment complies with the requirements of CEI/IEC 61010-1:2001-2 'Safety Requirements for Electrical Equipment for Measurement, Control and Laboratory Use'. If the equipment is used in a manner NOT specified by the Company, the protection provided by the equipment may be impaired.

Symbols

One or more of the following symbols may appear on the equipment labelling:

	Warning – Refer to the manual for instructions
	Caution – Risk of electric shock
	Protective earth (ground) terminal
	Earth (ground) terminal

	Direct current supply only
	Alternating current supply only
	Both direct and alternating current supply
	The equipment is protected through double insulation

Information in this manual is intended only to assist our customers in the efficient operation of our equipment. Use of this manual for any other purpose is specifically prohibited and its contents are not to be reproduced in full or part without prior approval of the Technical Publications Department.

Health and Safety

To ensure that our products are safe and without risk to health, the following points must be noted:

1. The relevant sections of these instructions must be read carefully before proceeding.
2. Warning labels on containers and packages must be observed.
3. Installation, operation, maintenance and servicing must only be carried out by suitably trained personnel and in accordance with the information given.
4. Normal safety precautions must be taken to avoid the possibility of an accident occurring when operating in conditions of high pressure and/or temperature.
5. Chemicals must be stored away from heat, protected from temperature extremes and powders kept dry. Normal safe handling procedures must be used.
6. When disposing of chemicals ensure that no two chemicals are mixed.

Safety advice concerning the use of the equipment described in this manual or any relevant hazard data sheets (where applicable) may be obtained from the Company address on the back cover, together with servicing and spares information.

Contents

1	Introduction	3
1.1	Functional Overview	3
2	Installation	5
2.1	Siting	6
2.2	Mounting	8
2.2.1	Panel-Mounting	9
2.2.2	Wall-Mounting	10
2.2.3	Pipe-Mounting (Optional)	11
2.3	Electrical Connections	12
2.3.1	Cable Entries	13
2.3.2	Connections	15
2.4	Analog/Digital Inputs	16
2.4.1	Thermocouple	16
2.4.2	Resistance Thermometer (RTD)	16
3	On-Line Help	18
4	Operation	19
4.1	Powering up the Instrument	19
4.2	Operator Keys and Door Features	19
4.3	Operator Display Overview	20
5	Logging	21
5.1	Logging Access	21
5.1.1	Password Entry	23
6	Configuration	24
6.1	Introduction	24
6.2	Configuration Level Security	24
6.3	Configuration Level Access	25
6.4	Overview of Configuration	28
6.5	Making Changes to Parameters	29
7	Specification	33
	Appendix A – Signal Sources	43

Appendix B – ModbusTCP Guide	45
B.1 Introduction	45
B.2 Modbus Commands Supported	45
B.3 Modbus Exception Responses	45
B.4 Operating Mode Modbus Coils	46
B.5 Operating Mode ModbusTCP Registers	50
B.6 Communications – Analog and Digital Inputs	52
Appendix C – Storage Capacity	55
C.1 Internal Storage Capacity	55
C.2 External Storage Capacity	55
Appendix D – Units	56
Index	58
Notes	60

1 Introduction

1.1 Functional Overview – Fig. 1.1

The instrument features the following functionality:

- 8 Software Recording Channels as standard, divided into 2 Process Groups, each with 4 Software Recording Channels.
- 4 Alarms and 2 Totalizers are assigned to each Recording Channel.
- Signal sources derived from universal analog inputs, Modbus communications, digital inputs or internal analog and digital signals.
- Any source can be assigned to any recording channel.
- Data from assigned sources can be displayed in:
 - Vertical or Horizontal Chart-view format
 - Indicator view format with optional integrated Bargraph view
- Three instrument logs record alarm events, totalizer values and system/configuration changes.
- Modbus TCP – communicate with Modbus master and slave devices over an ethernet LAN.
- Screen Capture facility – saves an image of the operator views to external archive media providing external archive media with sufficient free space is inserted in the instrument. It is not necessary for Logging to be 'online'.
- Internal flash memory for the storage of recorded data.
- The ability to archive data to external archive media in either text (*.csv) or binary formats.
- Integrated web server and file transfer protocol (ftp) support for remote monitoring and data acquisition.

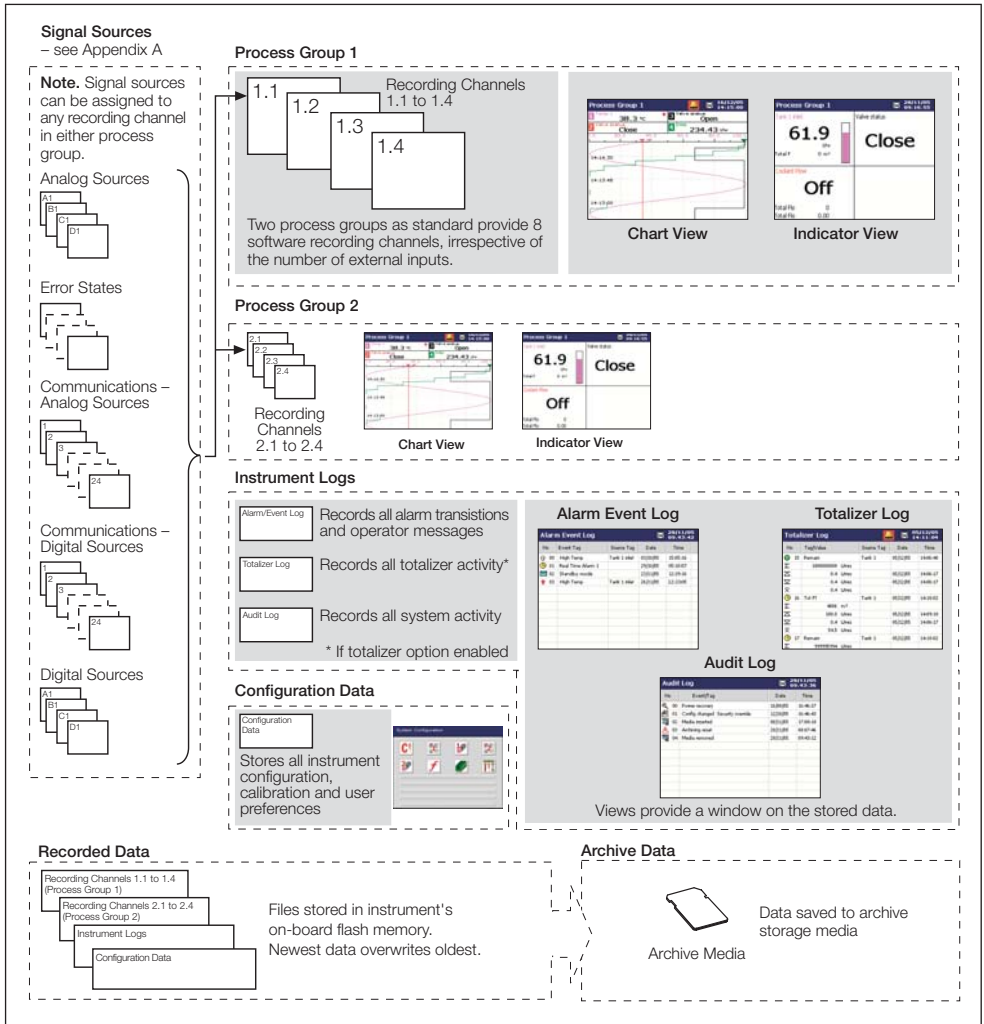

Fig. 1.1 Functional Overview

2 Installation

EC Directive 89/336/EEC

In order to meet the requirements of EC Directive 89/336/EEC for EMC regulations, this product must not be used in a non-industrial environment.

End of Life Disposal

- The instrument contains a small lithium battery that must be removed and disposed of responsibly in accordance with local environmental regulations.
- The remainder of the instrument does not contain any substance that causes undue harm to the environment and must be disposed of in accordance with the Directive on Waste Electrical and Electronic Equipment (WEEE). It must not be disposed of in Municipal Waste Collection.

Cleaning

The complete instrument can be hosed down if it has been installed to IP66/NEMA 4X standards, i.e. cable glands are correctly fitted and all unused cable entry holes are blanked off – see Section 2.3.1 on page 13. Warm water and a mild detergent can be used.

2.1 Siting – Fig. 2.1 and Fig. 2.2

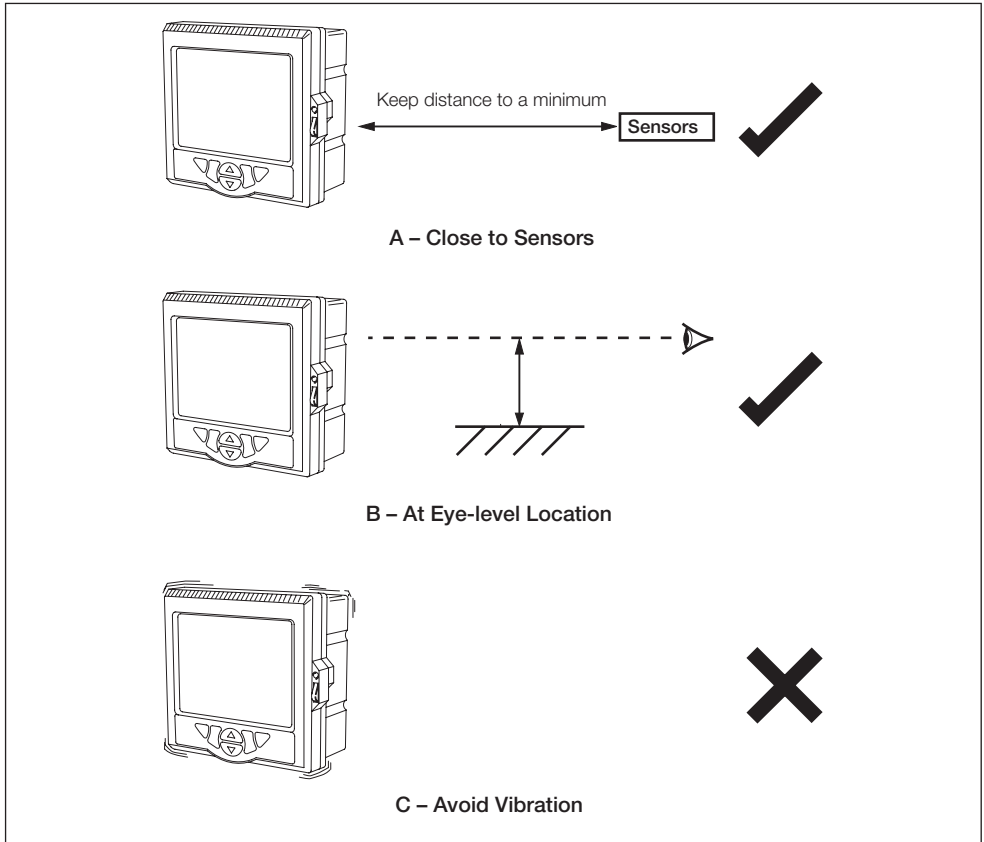

Fig. 2.1 General Siting Requirements

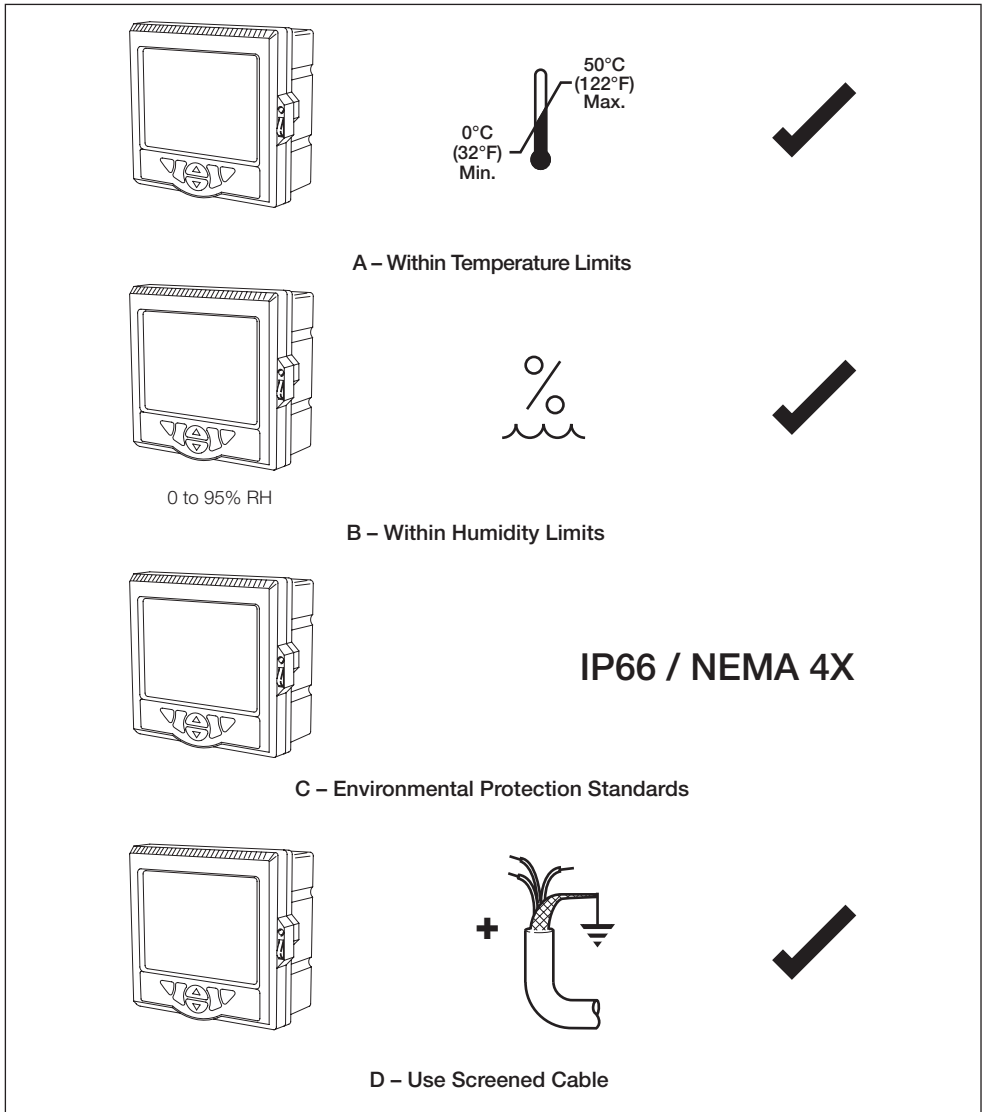

Fig. 2.2 Environmental Requirements

Warning. Select a location away from strong electrical and magnetic fields. If this is not possible, particularly in applications where mobile communications equipment is expected to be used, screened cables within earthed metal conduit must be used.

2.2 Mounting

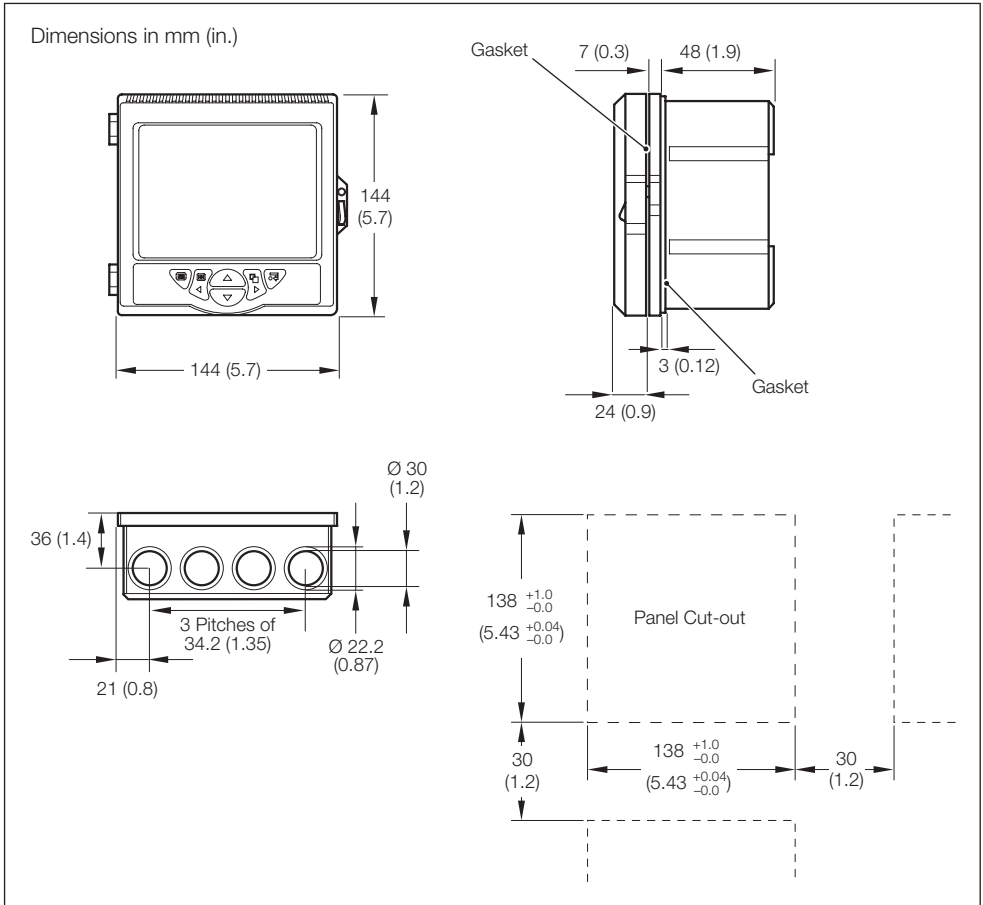

Fig. 2.3 Mounting Dimensions

2.2.1 Panel-Mounting – Fig. 2.4

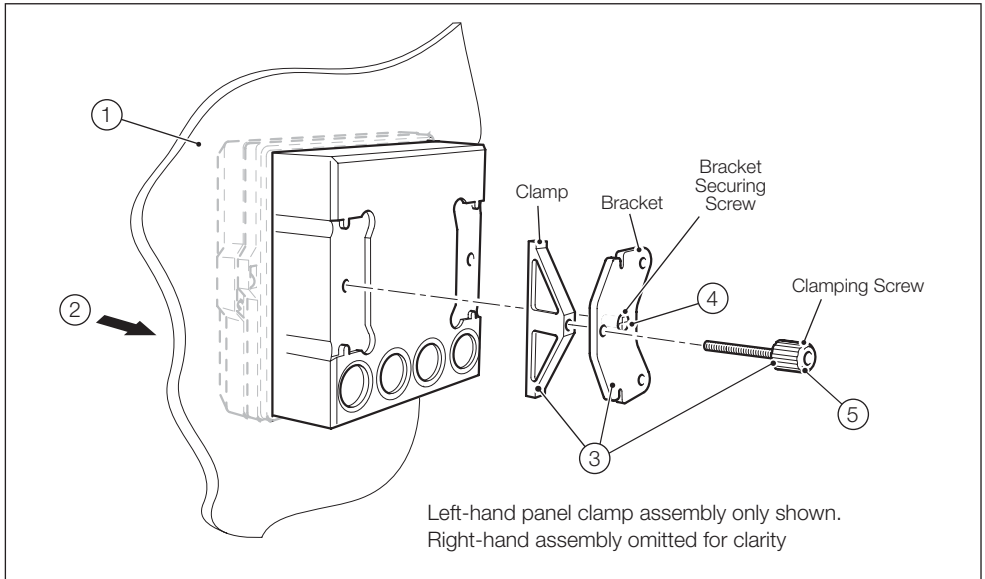

Fig. 2.4 Installing the Instrument – Panel-Mounting

Note. If removal of knockouts is required, refer to Section 2.3.1 on page 13.

Referring to Fig. 2.4, secure the instrument in a panel as follows:

- ① Cut the correct sized hole in the panel – see Fig. 2.3 on page 8.
 - ② Insert the instrument into the panel cut-out.
 - ③ Screw one clamping screw into the left-hand bracket until 10 to 15mm of the thread protrudes from the other side of the bracket and position one clamp over the end of the thread.
 - ④ Holding the assembly together, position the bracket into the left-hand recess on the rear of the instrument case and secure with the bracket securing screw. Ensure that the plastic washer remains in the position fitted.
- Repeat instructions ③ and ④ for the right-hand panel clamp assembly.
- ⑤ Tighten the clamping screws evenly and securely by hand.

Note. This is critical in order to ensure proper compression of the panel seal and achieve the IP66/NEMA 4X hosedown rating.

2.2.2 Wall-Mounting – Fig. 2.5

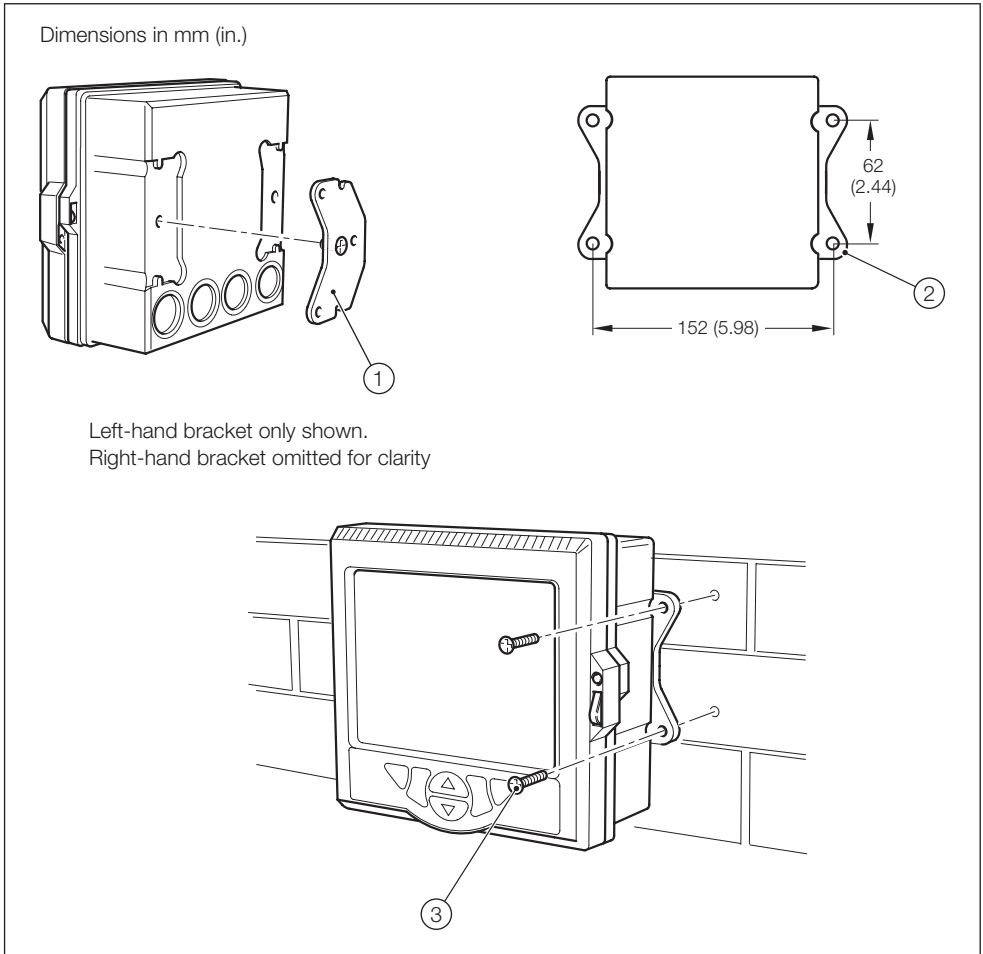

Fig. 2.5 Installing the Instrument – Wall-Mounting

Note. If removal of knockouts is required, refer to Section 2.3.1 on page 13.

Referring to Fig. 2.5, secure the instrument to a wall as follows:

- ① Position the left- and right-hand mounting brackets into the recesses on the rear of the instrument as shown and secure with the bracket securing screws. Ensure the plastic washers remain in the positions fitted.
- ② Mark fixing centers and drill suitable holes in the wall.
- ③ Secure the instrument to the wall using 2 screws in each mounting bracket.

2.2.3 Pipe-Mounting (Optional) – Fig. 2.6

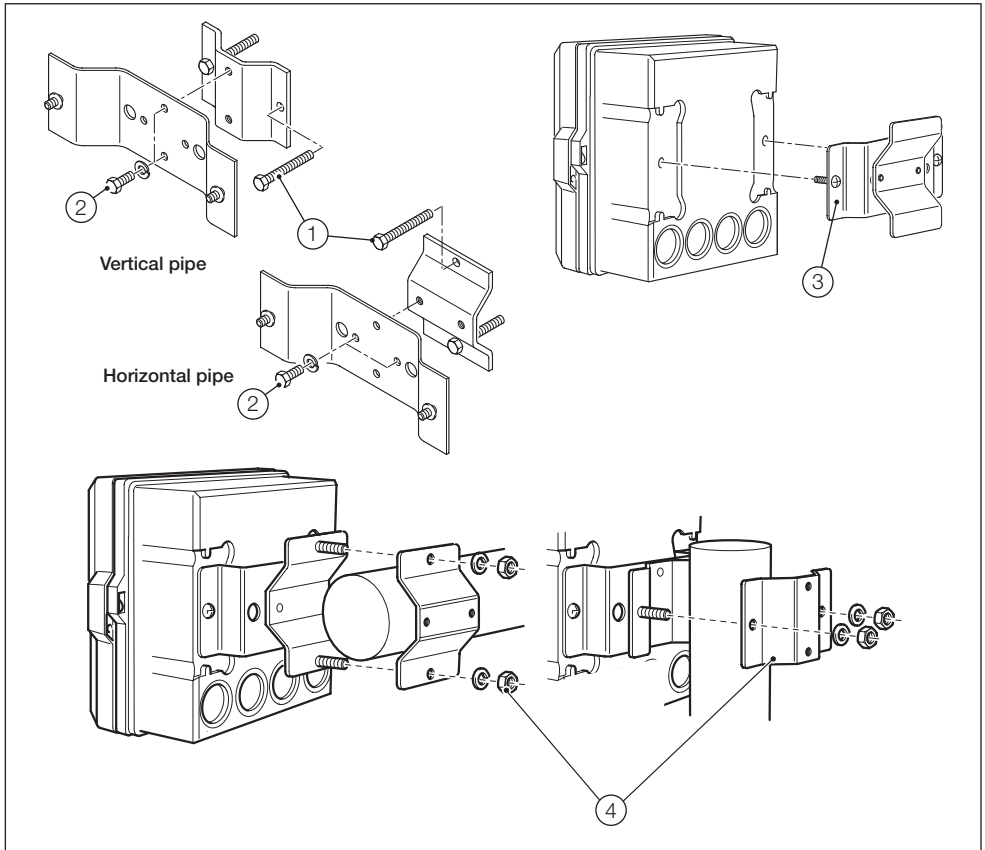

Fig. 2.6 Installing the Instrument – Pipe-Mounting (Optional)

Note. If removal of knockouts is required, refer to Section 2.3.1 on page 13.

Referring to Fig. 2.6, secure the instrument to a pipe as follows:

- ① Fit two M6 x 50mm long hexagon-head screws through one clamp plate as shown.
- ② Using the appropriate holes to suit vertical or horizontal pipe, secure the clamp plate to the pipe-mounting bracket using the two M6 x 8mm long hexagon-head screws and two of the spring lock washers.
- ③ Position the pipe mounting bracket into the recesses on the rear of the instrument as shown and secure with the two bracket securing screws. Ensure the plastic washers remain in the positions fitted.
- ④ Secure the instrument to the pipe using the remaining clamp plate, spring lock washers and nuts.

2.3 Electrical Connections

Warning.

- The instrument is not fitted with a switch therefore a disconnecting device such as a switch or circuit breaker conforming to local safety standards must be fitted to the final installation. It must be fitted in close proximity to the instrument within easy reach of the operator and must be marked clearly as the disconnection device for the instrument.
- Remove all power from supply, relay and any powered control circuits and high common mode voltages before accessing or making any connections.
- Use cable appropriate for the load currents. The terminals accept cables up to 14AWG (2.5mm²).
- The instrument conforms to Installation Category II of IEC 61010.
- All connections to secondary circuits must have basic insulation.
- After installation, there must be no access to live parts, for example, terminals.
- Terminals for external circuits are for use only with equipment with no accessible live parts.
- If the instrument is used in a manner not specified by the Company, the protection provided by the equipment may be impaired.
- All equipment connected to the instrument's terminals must comply with local safety standards (IEC 60950, EN601010-1).

Note.

- Always route signal leads and power cables separately, preferably in earthed (grounded) metal conduit.
- It is strongly recommended that screened cable is used for signal inputs and relay connections.

2.3.1 Cable Entries – Fig. 2.7

Referring to Fig. 2.7 on page 14:

- ① Route cables through the four holes provided on the bottom of the case.
- ② Knockouts are provided on the rear of the instrument case as an alternative means of cable entry. To remove a knockout, place the back of the instrument on a firm, flat surface, open the door and inner cover (see Fig. 6.3 on page 27) and carefully remove the knockout by placing the blade of a small, flat-bladed screwdriver into the knockout groove and tapping the screwdriver smartly with a hammer.
- ③ Use the indicated cable entry hole or knockout if the optional Ethernet module is fitted.
- ④ Connect the Ethernet cable, ensuring that if optional input modules are fitted in positions B and C, the cable is routed between their terminal blocks as shown.
- ⑤ Connect cable screens only to the terminals indicated.

Note.

- For wall- or pipe-mounting to IP66/NEMA4X standard, fit suitable cable glands. Blank off any unused holes with the blanking plugs and retaining clips supplied with the instrument.
- Optional cable glands are available and are suitable for use with cables Ø 5mm to 9mm (0.20 in. to 0.35 in.). The alternative 2-hole cable gland inserts are suitable for use with cables Ø 5mm (0.20 in.). The Ethernet cable gland is suitable for use with cable Ø 4.8mm to 6.3mm (0.19 in. to 0.25 in.).

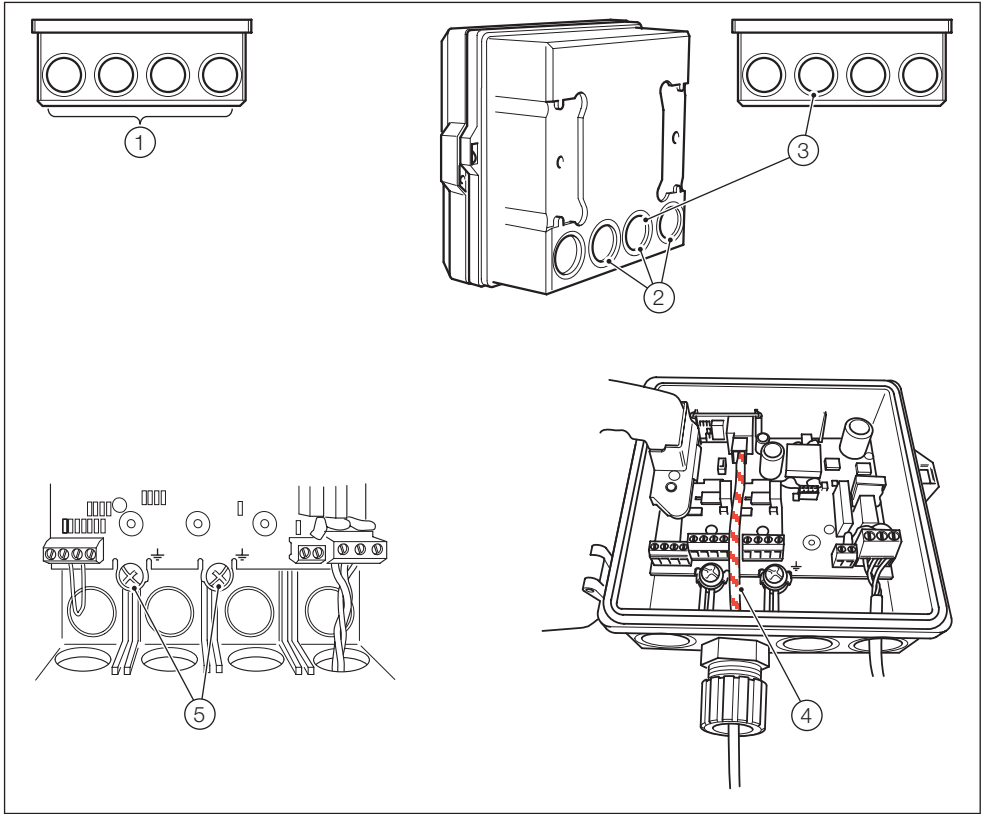

Fig. 2.7 Cable Knockouts, Ethernet Cable Routing and Cable Screening Connections

2.3.2 Connections – Fig. 2.8

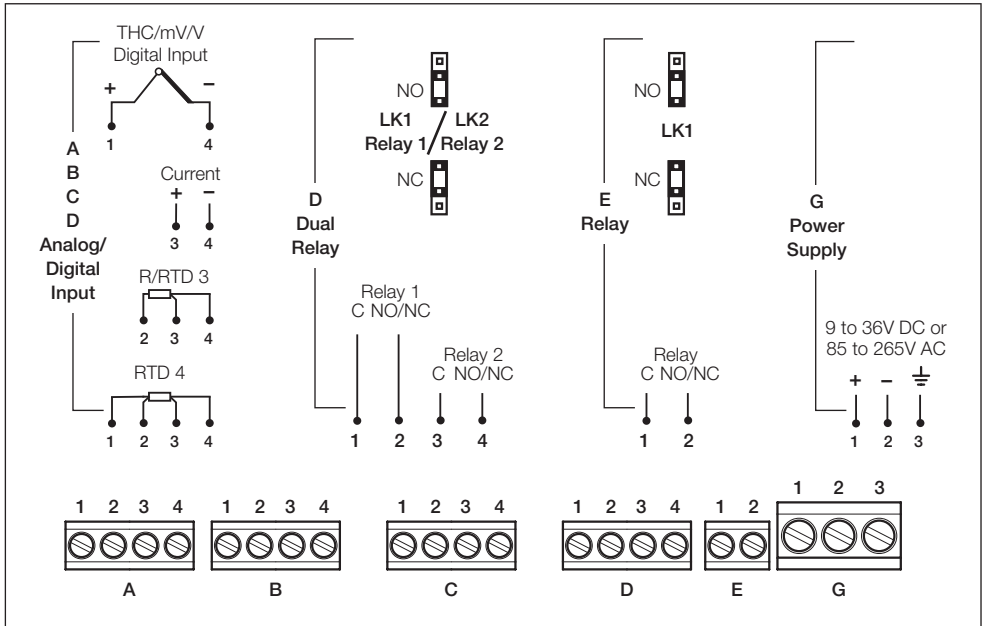

Fig. 2.8 Electrical Connections

2.4 Analog/Digital Inputs

2.4.1 Thermocouple – Fig. 2.9

Use the correct compensating cable between the thermocouple and the terminals – see Table 2.1 on page 17.

Automatic cold junction compensation (ACJC) is incorporated but an independent cold (reference) junction may be used.

2.4.2 Resistance Thermometer (RTD) – Fig. 2.9

On applications requiring long leads it is preferable to use a 3-lead resistance thermometer.

If 2-lead resistance thermometers are used, each input must be calibrated to take account of the lead resistance.

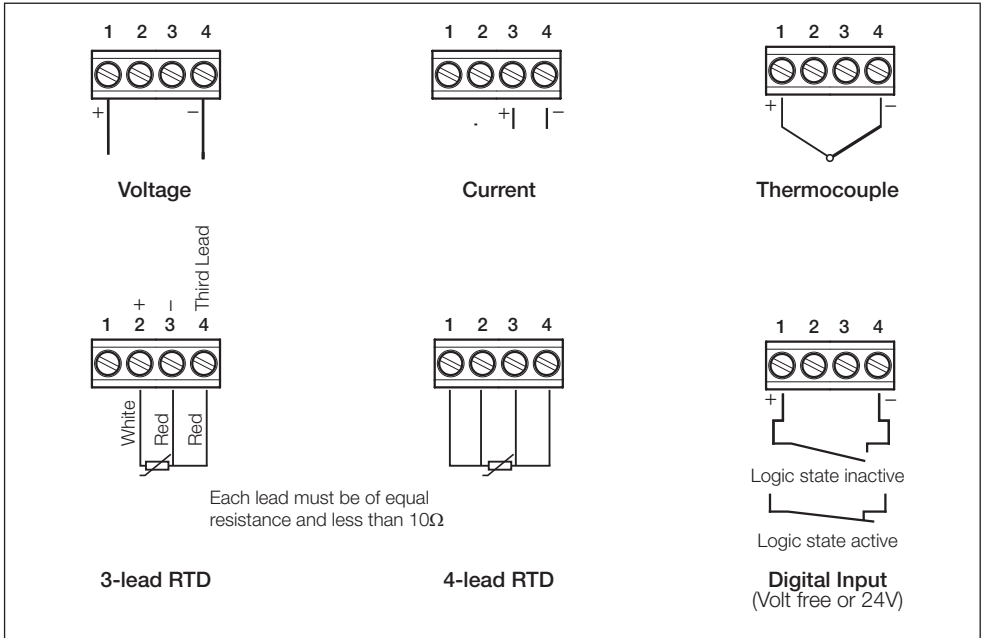

Fig. 2.9 Analog/Digital Input Connections

Thermocouple Type	Compensating Cable											
	BS1843			ANSI MC 96.1			DIN 43714			BS4937 Part No.30		
	+	-	Case	+	-	Case	+	-	Case	+	-	Case
Ni-Cr/Ni-Al (K)	Brown	Blue	Red	Yellow	Red	Yellow	Red	Green	Green	Green	White	Green *
Ni-Cr/Cu-Ni (E)	-			-			-			Violet	White	Violet *
Nicrisil/Nisil (N)	Orange	Blue	Orange	Orange	Red	Orange	-			Pink	White	Pink *
Pt/Pt-Rh (R and S)	White	Blue	Green	Black	Red	Green	Red	White	White	Orange	White	Orange *
Pt-Rh/Pt-Rh (B)	-			-			-			Grey	White	Grey *
Cu/Cu-Ni (T)	White	Blue	Blue	Blue	Red	Blue	Red	Brown	Brown	Brown	White	Brown *
Fe/Con (J)	Yellow	Blue	Black	White	Red	Black	Red	Blue	Blue	Black	White	Black *
* Case Blue for intrinsically safe circuits												
Fe/Con (DIN 43710)	-			-			DIN 43710			-		
							Blue/red	Blue	Blue			

Table 2.1 Thermocouple Compensating Cable

3 On-Line Help

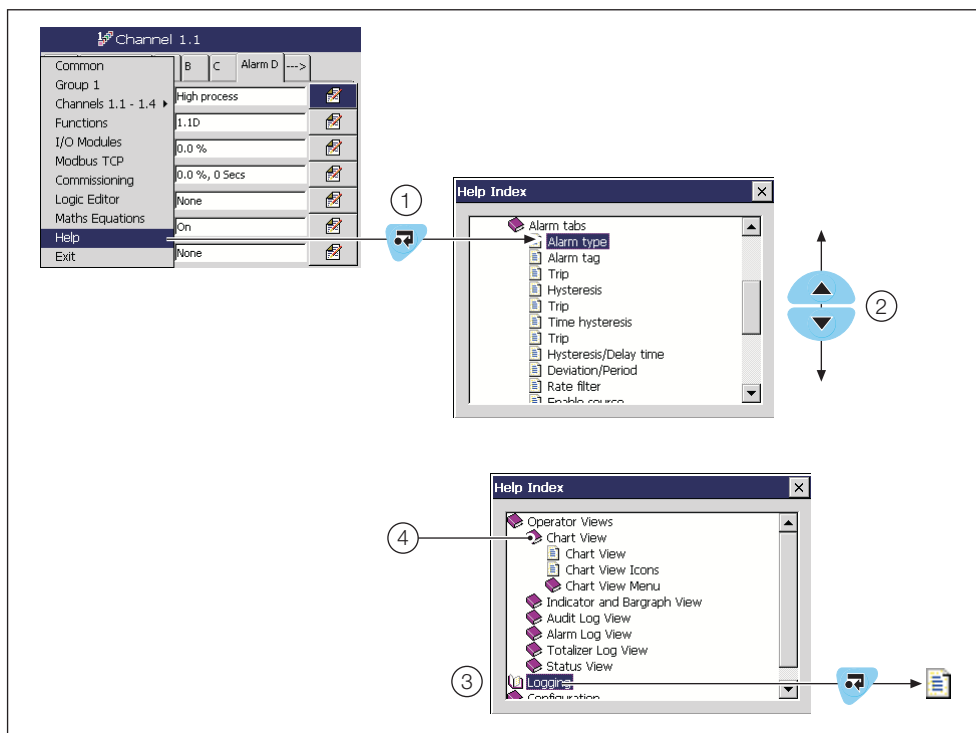

Fig. 3.1 On-Line Help Overview

The instrument is equipped with a context-sensitive, on-line help facility that can be accessed from any operator, logging or configuration view. To navigate the on-line help, refer to Fig. 3.1 and:

- ① Select 'Help' from the menu and press the key. The help index opens automatically at the help page relevant to the view from which help was selected – in this instance, the alarm configuration view.
- ② Press the and keys to move the selection up and down through the index. Press the key to view the selected help file and use the and keys to scroll through it.
- ③ Highlight a section icon (). If it changes to the icon, there is a help file () directly associated with selected section – press the key to open it.
- ④ If the section icon remains closed, the section it represents contains sub-sections and files. Press the key to open the section and reveal the sub-sections. Repeat the process for sub-sections. Press the key to close a sub-section or section.

To exit the on-line help, press the key repeatedly to return to the screen from where help was first selected.

4 Operation

4.1 Powering up the Instrument

When power is first applied to the instrument, its processor carries out a number of self-tests and displays the start-up screen.

At the end of the start-up sequence, the instrument displays the Operator View that was being displayed when the instrument was powered down.

4.2 Operator Keys and Door Features – Fig. 4.1

The instrument is operated via the Operator Keys located below the screen.

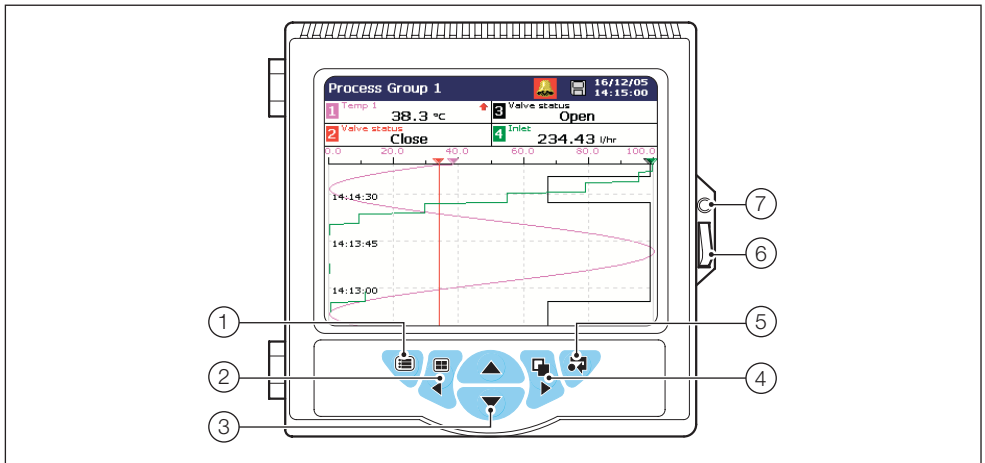

Fig. 4.1 Operator Keys and Door Features

Referring to Fig. 4.1, operator keys and door features are located as follows:

- ① Menu Key – Displays or hides the context-sensitive operator menu associated with each view. Also cancels the menu without making a change or returns to the previous menu level.
- ② Group Key – Selects a different process group or
 - ◀ Left Key – Scroll left.
- ③ Up/Down Keys – Highlights menu items and scrolls through previously recorded data.
- ④ View Key – Selects a different process view or log or
 - ▶ Right Key – Scroll right.
- ⑤ Enter Key – Selects the highlighted menu item. If 'Screen Capture' is set to 'Enabled' during configuration and external archive media is inserted in the instrument, the operator can save a snapshot of any operator view to the external media if pressed when an operator menu is not displayed.
- ⑥ Door Release.
- ⑦ Door Lock (optional).

4.3 Operator Display Overview – Fig. 4.2

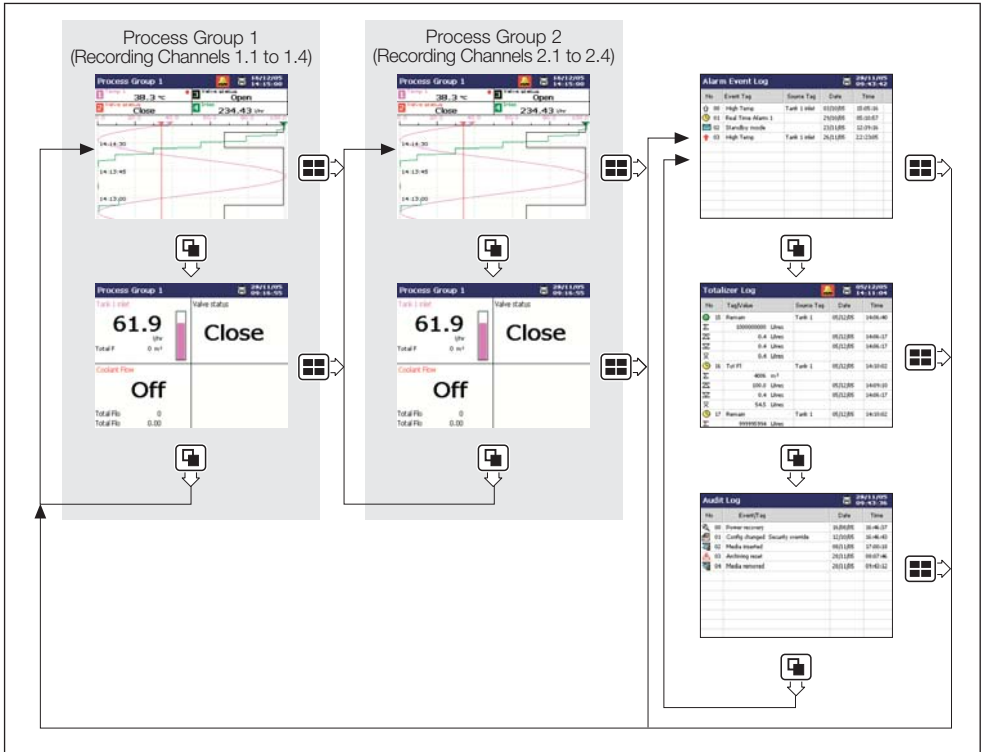

Fig. 4.2 Overview of Operator Displays

Note. Only process groups and views that are enabled are displayed.

5 Logging

5.1 Logging Access

Access to Logging is controlled by the instrument's Security System.

- If 'Security System' is set to 'Basic' and 'Logging Security' is set to 'Off', access to the Logging facility is unrestricted.
- If 'Security System' is set to 'Basic' and 'Logging Security' is set to 'On', access to the Logging facility is protected by a single password for all users. Refer to Fig. 5.1 to access Logging.
- If 'Security System' is set to 'Advanced' and 'Logging Security' is set to 'On', access to the Logging facility is protected by a unique password for each authorized user. Refer to Fig. 5.2 on page 22 to access Logging.

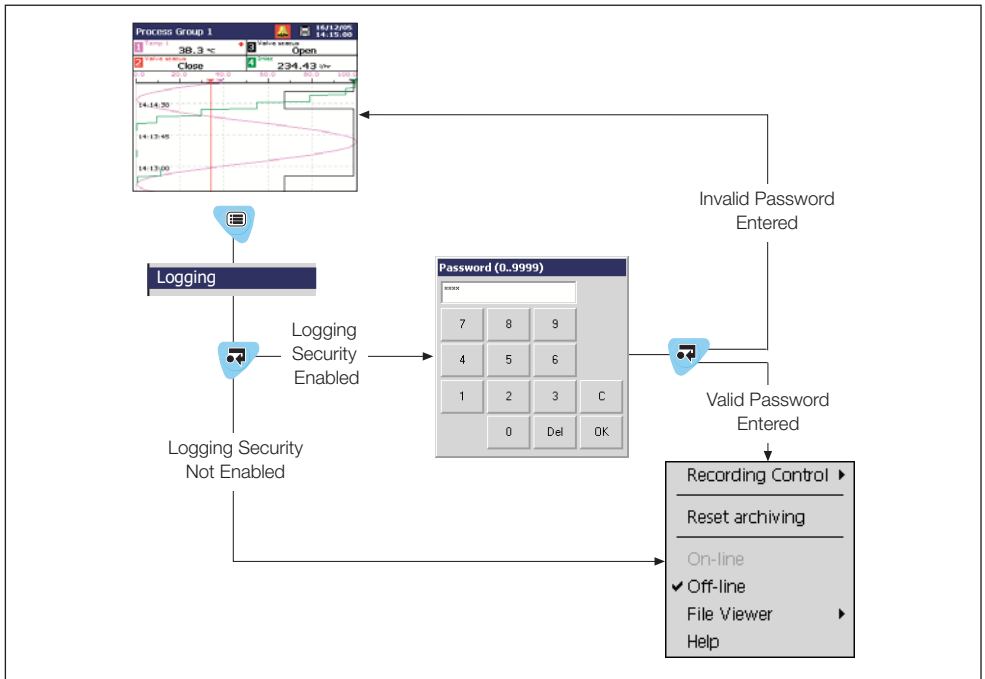

Fig. 5.1 Accessing Logging – Basic Security

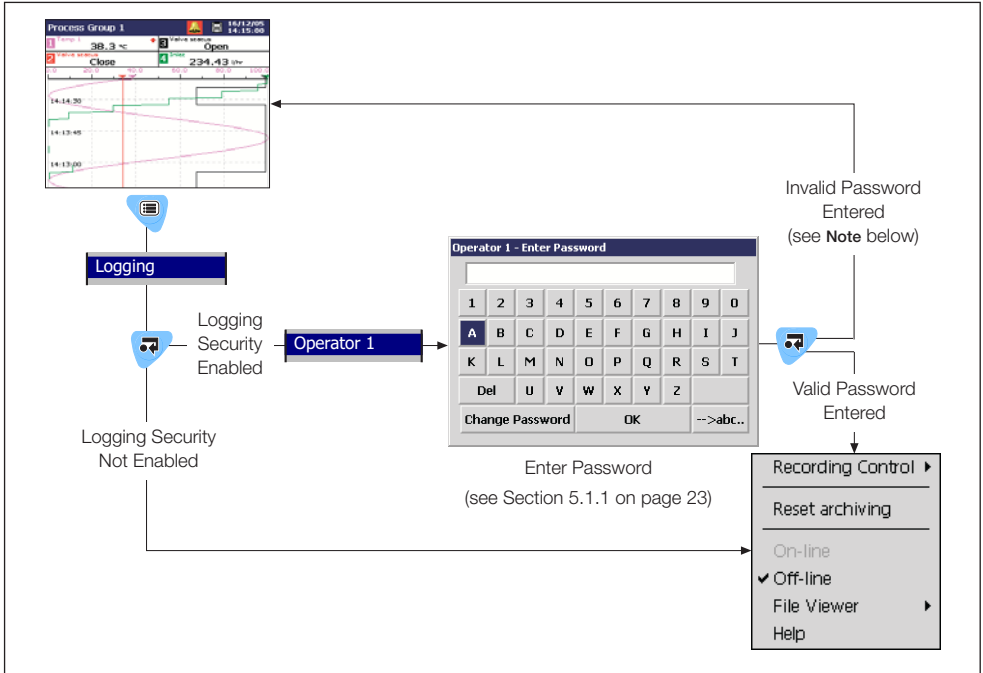

Fig. 5.2 Accessing Logging – Advanced Security

Note. If an incorrect password is entered the display returns to the Operating view. However, if the maximum number of consecutive incorrect password entries is exceeded, the user's access privileges are removed and the following message is displayed:



If this occurs, access privileges can be reinstated only by the system administrator (User 1). If the system administrator's access privileges have been removed, the security system must be disabled using the configuration security switch to gain access to the configuration.

5.1.1 Password Entry



Enter password

1. Select the required character using the , , and keys.
 2. Add the selected character to the password string using the key.
- Note.** For security, all characters are displayed as 'i'
3. Repeat 1 and 2 until all characters have been entered.
 4. Highlight the 'OK' button using the , , and keys and press .



Change password

1. Select 'Change Password' using the , , and keys and press .
2. Highlight the Edit Button () using the and keys and press to display the character entry box.
3. Enter the old password using the , , and keys. Highlight the 'OK' button and press .
4. Enter the new password using the same procedure as for the old password.
5. Enter the new password again to confirm it.
6. Highlight the 'OK' button and press .

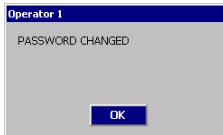
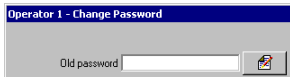

Password change successful.

Note. If the \ key is pressed at any stage or 'OK' is selected before the new password is confirmed, the password change operation is cancelled and the following message is displayed:

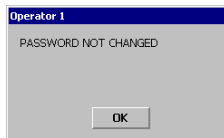

Password Expired

Passwords can be configured to expire at pre-determined intervals. If a password is time expired, this screen is displayed automatically. Enter a new password as described above.



6 Configuration

6.1 Introduction

This section describes how to access the instrument's configuration level and make changes to the parameters using the operator keys.

6.2 Configuration Level Security – Table 6.1

Two methods of configuration access protection are available:

1. Password protection (Factory Default).

The Configuration level cannot be accessed until the correct password has been entered – see Figs. 6.1 and 6.2 on pages 25 and 26 respectively.

2. Internal switch protection.

The Configuration level cannot be accessed until the internal switch set to the 'Configuration Level Not Protected' position – see Fig. 6.3 on page 27.

	'Configuration security' Parameter Setting	
Internal Security Switch Setting (see Fig. 6.3)	'Password protected' (Factory Default)	'Switch protected' (Alternative)
Configuration Level Protected (Factory Default)	Password Access	No Access
Configuration Level Not Protected	Free Access	Free Access

Table 6.1 Configuration Security Modes

The instrument can be configured for one of two levels of password protection:

Basic Security:

- Up to 4 users
- Each user is assigned a unique 4-digit security code for Configuration level access
- Optional security code protection of access to the logging facility

Advanced Security:

- Up to 12 users
- Each user is assigned a unique password of up to 20 characters
- Each user is assigned configuration and/or logging access privileges
- Each user is assigned one of 3 levels of configuration level access privileges
- Configurable password expiry times, password failure limits and minimum password length
- Inactive user disabling

6.3 Configuration Level Access – Figs. 6.1 to 6.3

To configure an instrument when 'Configuration security' is set to the factory default setting of 'Password protected':

1. Access the Configuration Level – see Figs. 6.1 and 6.2 on pages 25 and 26 respectively.
2. Make changes to parameters as detailed in Figs 6.5 and 6.6 (on pages 29 and 30 respectively) and on-line help.

To configure an instrument when 'Configuration security' is set to 'Internal switch protected':

1. Set the internal security switch to the 'Configuration Level Not Protected' position – see Fig. 6.3.
2. Access the Configuration Level – see Figs. 6.1 and 6.2 on pages 25 and 26 respectively.
3. Make changes to parameters as detailed in Figs 6.5 and 6.6 (on pages 29 and 30 respectively) and on-line help.

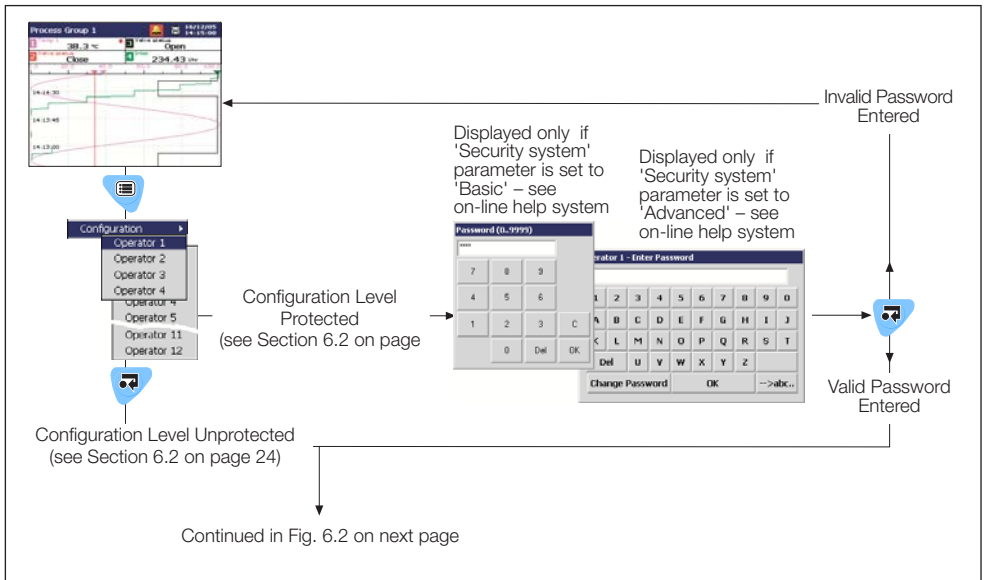

Fig. 6.1 Accessing the Configuration Level

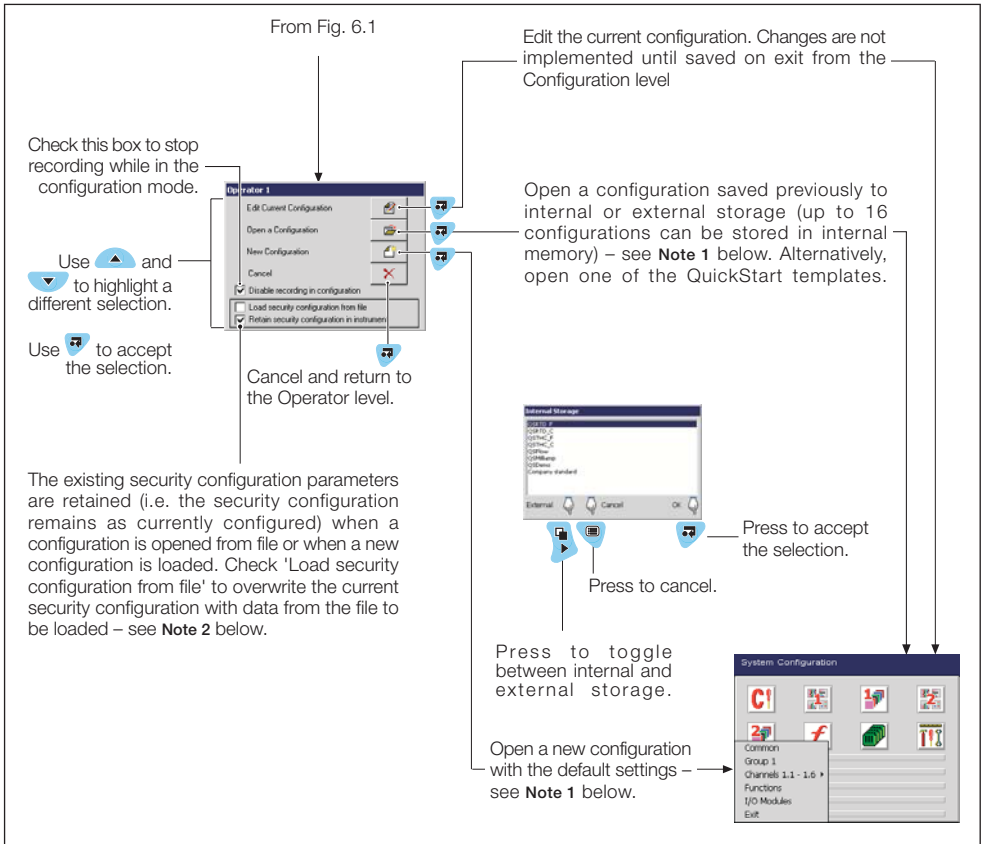

Fig. 6.2 Accessing the Configuration Level

Note.

1. If 'New Configuration' or 'Open a Configuration' is selected and the modified configuration file is saved later as the current configuration, new internal data files for all enabled recording channels are created and any unarchived data is lost.
2. The option to load or retain the security configuration applies only to Advanced Security mode and is available only to the System Administrator (User 1). If a new or existing configuration file is opened by a user other than the System Administrator, the instrument's existing security settings are retained.

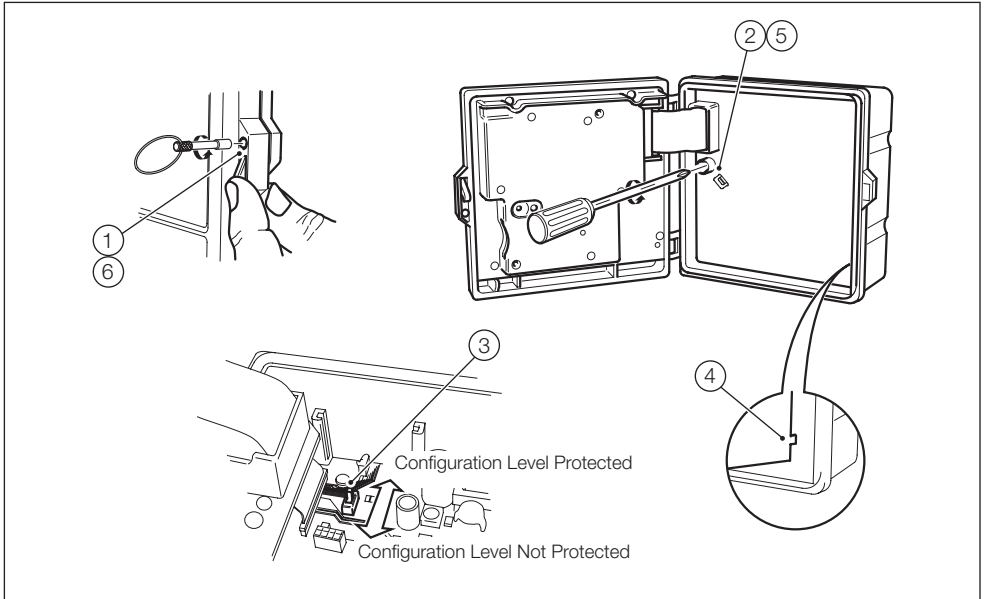

Fig. 6.3 Setting the Security Switch

Referring to Fig. 6.3, set the internal security switch as follows:

- 1 Unlock the instrument door with the key supplied, press the release catch and open the door.

Warning. Before proceeding to step 2, isolate the instrument from the power supply.

- 2 Remove the tamper-evident seal (if fitted), release the captive screw securing the inner cover plate and remove the inner cover plate.
- 3 Set the Security switch to the 'Configuration Level Not Protected' position (toward bottom of instrument).

Note. The Internal Security Switch is used to access the Configuration level when 'Configuration security' is set to 'Switch protected'. Do Not use the switch to access the Configuration level when 'Configuration security' is set to 'Password protected' (default setting) unless the Password has been forgotten. The switch overrides Password protection, enabling free access to the Configuration level.

- 4 Locate the inner cover plate lugs in the slots in the outer case and close the inner cover plate.
- 5 Tighten the inner cover plate retaining screw and fit a tamper-evident seal (if required).
- 6 Close and lock the instrument door and restore the power supply to the instrument.

6.4 Overview of Configuration – Fig. 6.4

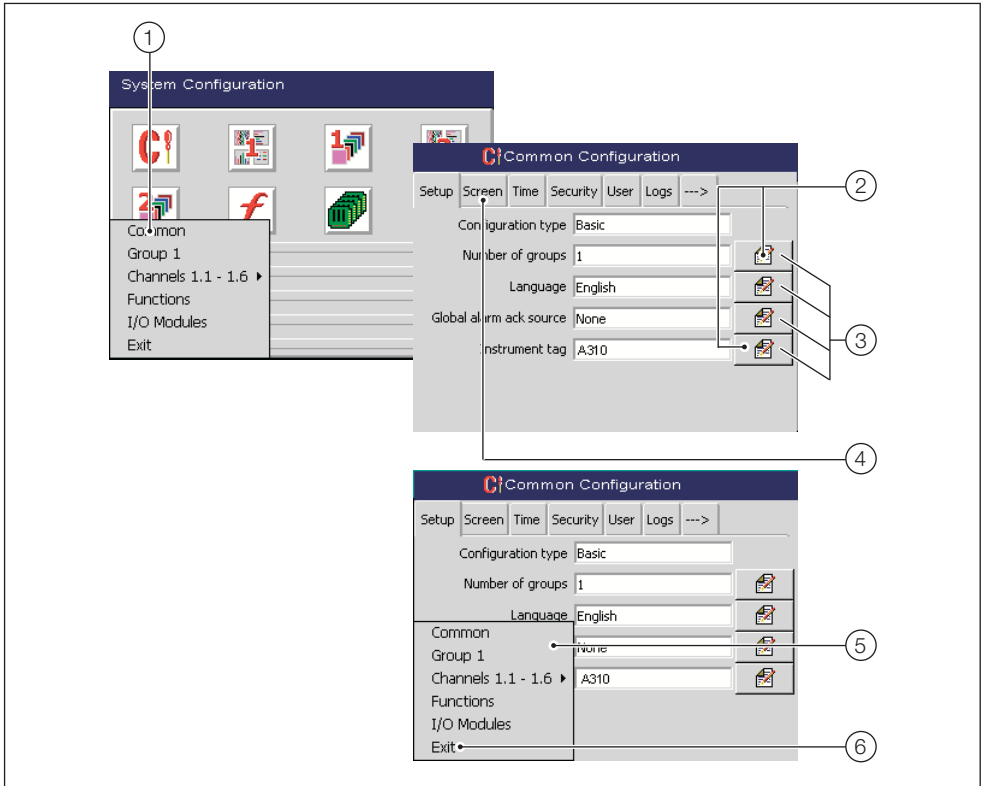





Fig. 6.4 Overview of Configuration Steps

Referring to Fig. 6.4, configure the instrument as follows:

- ① Select 'Common' from the Configuration menu.

Note. Only enabled Process Groups (and their associated Channel Options) and enabled software options (i.e. Math and Logic) are visible in the menu.

- ② Select the parameter required using the ▲ and ▼ keys.
- ③ Press the  key to edit selected parameter.
- ④ Use the ◀ and ▶ keys to select the next required tab.
- ⑤ Press the  key to display the menu. Select the next item required and activate using the  key.
- ⑥ When all configuration changes are complete select 'Exit' to save or cancel changes.

6.5 Making Changes to Parameters – Figs. 6.5 to 6.7

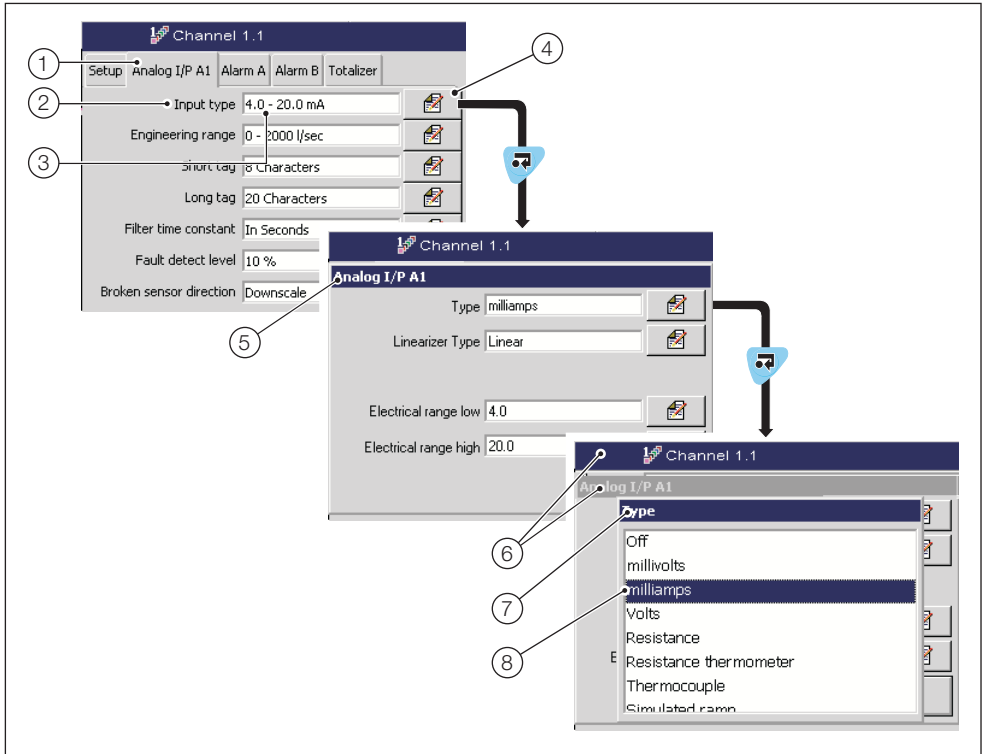

Fig. 6.5 Locating Parameter Settings

Referring to Fig. 6.5, parameters are located as follows:

- ① Configuration tab.
- ② Parameter.
- ③ Parameter value.
- ④ Edit button.
- ⑤ Sub-menu.
- ⑥ Higher-level windows remain visible to identify location within the configuration structure.
- ⑦ Selection list.
- ⑧ Use the ▲ and ▼ keys to highlight a selection. Press the ⏎ key to accept the selection.

Note.

- The appropriate data entry box is displayed automatically.
- Use the ☰ key to open the Configuration menu in order to select a different channel.

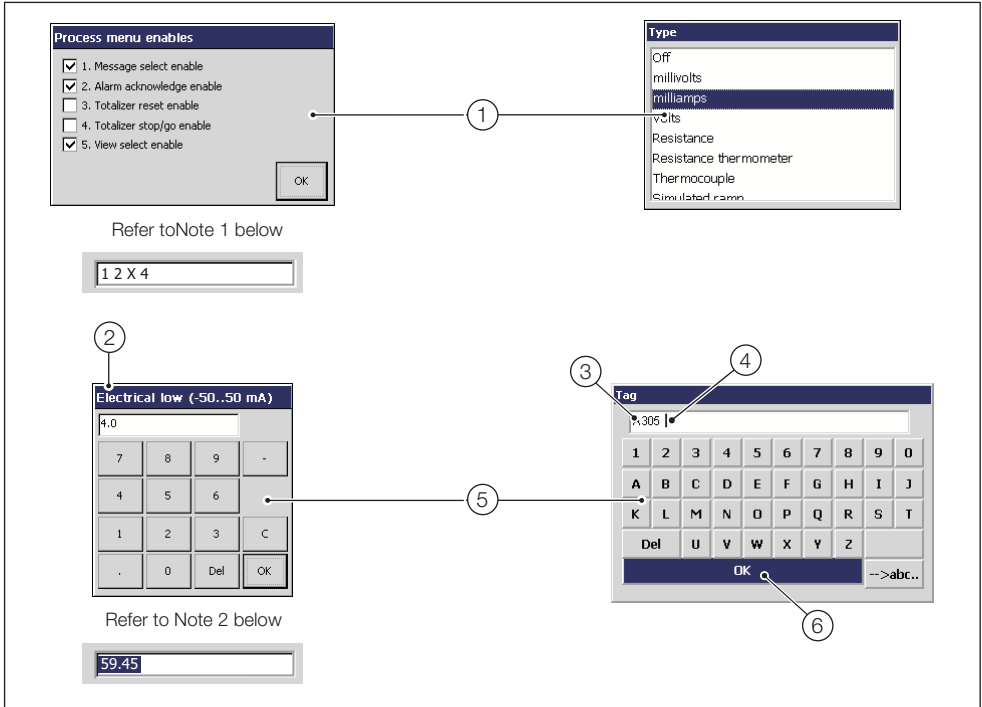

Fig. 6.6 Data Entry Dialog Boxes

Note.

1. Items not selected are indicated by an X in the parameter value window.
2. Values outside the preset parameter limits or with too many decimal places are highlighted when the OK button is selected.

Referring to Fig. 6.6, use data entry dialog boxes as follows:

- ① Use the ▲ and ▼ keys to highlight an item and press to select it.
- ② Parameter limits.
- ③ Use the ▲ and ▼ keys to highlight the text field and use the ◀ and ▶ keys to position the cursor to edit text as required.
- ④ Cursor.
- ⑤ Use the ▲, ▼, ◀ and ▶ keys and press to highlight a character and press to select it.
- ⑥ Spacebar.

Note. Tags with a high percentage of capital letters and wide characters such as 'W' or 'M' may appear truncated in some Operator Views. In such cases, use lower case letters or fewer characters.

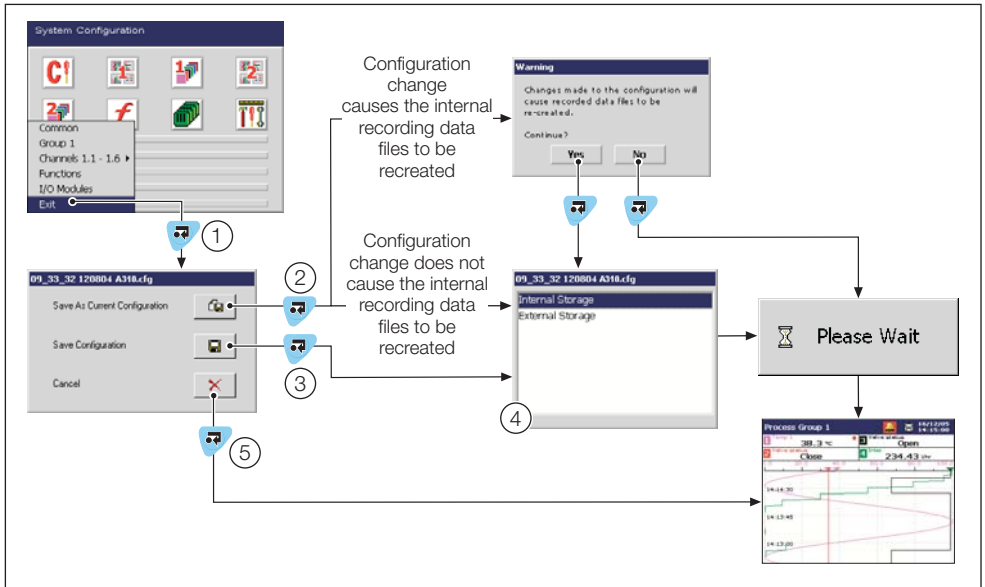

Fig. 6.7 Exiting Configuration Mode

Referring to Fig. 6.7, exit configuration mode as follows:

- ① Open the menu, select 'Exit' and press .
- ② To begin using a configuration immediately, select 'Save as Current Configuration'.

Note.

- New internal data files for enabled recording channels are created if:
 - A recording channel source parameter is changed
 - The primary and/or secondary sample rates and/or their sources for either process group are changed.
 - The input filter type parameter for any channel is changed
 - the engineering range parameter for any channel is changed
 - A channel tag parameter is changed
 - The number of process groups is changed
 - A previously disabled channel is enabled

A warning is displayed if a configuration change will result in the creation of new data files. Select 'Yes' to accept the changes or 'No' to reject them.

- Selecting 'Save as Current Configuration' suspends recording for a short time while the new configuration is implemented.

- ③ Select 'Save configuration' to save any changes but to continue to use the previous configuration.

Continued on next page...

- ④ Save the configuration in internal or external storage.

Note.

- A configuration file is saved with the filename '<time><date><instrument tag>A305.cfg'.
- When a current configuration is saved to external storage, it is also saved automatically to internal storage.

- ⑤ Select 'Cancel' to discard all changes and return to the Operating level.

7 Specification

Operation and Configuration

Configuration

Via tactile membrane keys on front panel or PC Configuration

Multiple configuration files can be stored in internal (up to 16 files) or external memory (with removable media option fitted)

Security

Physical

Optional lock on door

Configuration security

Password protection Access to configuration is allowed only after the user has entered a password

Internal switch protection Access to configuration is allowed only after a hardware switch has been set. This switch is situated behind a tamper-evident seal

Logging security

Configuration Can be configured for password protection or free access to logging levels

Basic type security

4 individual users with unique usernames and passwords

Advanced type security

Number of users Up to 12

Usernames Up to 20 characters. Usernames are unique (names cannot be repeated)

Access privileges Logging access – Yes/No
Configuration access
None/Load file only/Limited/Full

Passwords Up to 20 characters
A minimum required password length of 4 to 20 characters can be configured and a password expiry time can be applied to eliminate password ageing

Password failure limit Configurable for 1 to 10 consecutive occasions or 'infinite'
A user is deactivated if a wrong password is entered repeatedly

Deactivation of inactive users Can be disabled or configured for 7, 14, 30, 60, 90, 180 or 360 days of inactivity
Users are deactivated (by removal of access privileges) after a period of inactivity

Custom Linearization

Number

2

Number of breakpoints

20 per linearizer

Operator Messages

Number

24

Trigger

Via front panel or digital signals

Recording in alarm/event log

Can be enabled or disabled on configuration

Display

Monochrome FSTN or Color TFT, passive matrix, liquid crystal display (LCD) with built-in backlight and contrast adjustment

Diagonal display area	color 144mm (5.7 in.) monochrome 120mm (4.7 in.)
-----------------------	---

76800 pixel display*

* A small percentage of the display pixels may be either constantly active or inactive. Max. percentage of inoperative pixels <0.01%.

Language

English, German, French, Italian and Spanish

Dedicated operator keys

- Group select/Left cursor
- View select/Right cursor
- Menu key
- Up/Increment key
- Down/Decrement key
- Enter key

Chart screen intervals

Selectable from 18s to 7 days

Chart divisions

Programmable for up to 10 major and 10 minor divisions

Chart annotation

Alarm and operator messages may be annotated on the chart

Icons to identify the type of event, time of occurrence and tag are displayed

Process Alarms

Number

16 (4 per recording channel)

Types

High/Low process, latch & annunciator

Rate fast/slow

Tag

20-character tag for each alarm

Hysteresis

Programmable value and time hysteresis (1 to 9999s)

Alarm enable

Allows alarm to be enabled/disabled via a digital input

Alarm log enable

Recording of alarm state changes in the alarm/event log can be enabled/disabled for each alarm

Acknowledgement

Via front panel keys or digital signals

Real-time Alarms

Number

4

Programmable

Day of the week, 1st of month, start and duration times

Recording to Internal Memory

Data Channels

Internal buffer memory

8Mb Flash memory provides storage for 2 million samples

Oldest data is overwritten automatically by new data when memory is full

Data integrity checks

Checksum for each block of data samples

Independent process groups

2

No. of recording channels

4 per group

Sources

Analog inputs, Modbus™ inputs, any digital signal, math block

Filters

Programmable for each channel to allow recording of: instantaneous values, average, max., min. and max. & min. value over sample time

Primary/Secondary sample rates

Programmable from 0.1s to 12 hours for each process group

Primary/Secondary sample rate selection

Via any digital signal or from password protected menu

Recording start/stop control

Via any digital signal or from password-protected menu

Recording Duration

Approximate duration calculated for continuous recording of 4 channels of analog data (for 8 channels divide by 2, for 2 channels multiply by 2 etc.)

Sample Rate	1s	10s	40s	60s	120s	480s
8Mb Internal Flash Buffer Memory	6 days	2 months	7.5 months	1 year	2 years	7 years

Archiving to Removable Media

Removable storage media options

- SD Card

Data that can be saved to removable media

- Recorded data for group 1 & 2 channels
- Alarm event log data
- Totalizer log data
- Audit log data
- Configuration
- Screen capture images

File structure

Configurable as either binary-encoded or comma-separated

Filename

20-character tag, prefixed with date/time

Data verification

Carried out automatically on all writes to removable-media files

Recording Duration

Approximate duration calculated for continuous recording of 4 channels of analog data
(for 8 channels divide by 2, for 2 channels multiply by 2 etc.)

Binary Encoded File

Sample Rate	1s	10s
128Mb SD	3 months	2.5 years
256Mb SD	6 months	5 years

Sample Rate	1s	10s
512Mb SD	12 months	10 years
1Gb SD	2 years	20 years

Comma-separated File

Sample Rate	1s	10s
128Mb SD	20 days	6 months
256Mb SD	40 days	12 months

Sample Rate	1s	10s
512Mb SD	2.5 months	2 years
1Gb SD	5 months	4 years

Historical logs

Types

Alarm/Event, Totalizer and Audit logs

No. of records in each historical log

Up to 200 in internal memory

Oldest data is overwritten automatically by new data when log is full

Log Type	Alarm/Event Log		Totalizer Log		Audit Log	
Log Entry Events	Alarm state changes Operator messages		User-defined logging intervals Totalizer stop/start, reset, wrap Power up/down		Configuration/calibration changes System events Errors, operator actions	
	In Log	On Screen	In Log	On Screen	In Log	On Screen
Information Recorded in Log						
Date & time of event	4	4	4	4	4	4
Type of event	4	4	4	4	4	4
Tag	4	4	4	4	–	–
Source tag	4	–	4	–	–	–
Alarm trip value & units of measure	4	–	–	–	–	–
Alarm state	4	4	–	–	–	–
Alarm acknowledgement state	4	–	–	–	–	–
Operator ID	4	–	–	–	4	4
Description	–	–	–	–	4	4
Batch total and units of measurement*	–	4	4	–	–	–
Max., min. and average values plus units*	–	4	4	–	–	–
Secure total	–	–	4	–	–	–

* If Totalizer option is fitted and selected

Analog Inputs

General

Number of inputs

4 (1 as standard, 3 optional)

Input types

mA, mV, voltage, resistance, THC, 3-wire RTD, 4-wire RTD

Thermocouple types

B, E, J, K, L, N, R, S, T

Resistance thermometer

PT100

Other linearizations

\sqrt{x} , $x^{3/2}$, $x^{5/2}$, custom linearization

Digital filter

Programmable 0 to 60s

Display range

-99999 to +999999

Common mode noise rejection

>120dB at 50/60Hz with 300 Ω imbalance resistance

Normal (series) mode noise rejection

>60dB at 50/60Hz

CJC rejection ratio

0.05 $^{\circ}$ C/ $^{\circ}$ C

Sensor break protection

Programmable as upscale or downscale

Temperature stability

0.02%/ $^{\circ}$ C or 2 μ V/ $^{\circ}$ C

Long term drift

<0.2% of reading of 20 μ V annually

Input impedance

>10M Ω (millivolts inputs)

500k Ω (voltage inputs)

10 Ω (mA inputs)

Standard Analog Input Modules

Linear Inputs	Standard Analog Input	Accuracy (% of reading)
Millivolts	0 to 150mV	0.1% or \pm 20 μ V
Milliamps	0 to 50mA	0.2% or \pm 4 μ A
Volts	0 to 25V	0.2% or \pm 1mV
Resistance Ω (low)	0 to 550 Ω	0.1% or \pm 0.1 Ω
Resistance Ω (high)	0 to 10k Ω	0.1% or \pm 0.5 Ω
Sample Interval	100ms per sample	
Input Isolation	500V DC channel-to-channel	
Isolation from Rest of Instrument	Galvanically isolated to 500V DC	

Analog Input Types

Thermocouple	Maximum Range °C	Maximum Range °F	Accuracy (% of reading)
B	-18 to 1800	0 to 3270	0.1% or $\pm 2^{\circ}\text{C}$ (3.6°F) (above 200°C [392°F])
E	-100 to 900	-140 to 1650	0.1% or $\pm 0.5^{\circ}\text{C}$ (0.9°F)
J	-100 to 900	-140 to 1650	0.1% or $\pm 0.5^{\circ}\text{C}$ (0.9°F)
K	-100 to 1300	-140 to 2350	0.1% or $\pm 0.5^{\circ}\text{C}$ (0.9°F)
L	-100 to 900	-140 to 1650	0.1% or $\pm 1.5^{\circ}\text{C}$ (2.7°F)
N	-1200 to 1300	-325 to 2350	0.1% or $\pm 0.5^{\circ}\text{C}$ (0.9°F)
R	-18 to 1700	0 to 3000	0.1% or $\pm 1^{\circ}\text{C}$ (1.8°F) (above 300°C [540°F])
S	-18 to 1700	0 to 3000	0.1% or $\pm 1^{\circ}\text{C}$ (1.8°F) (above 200°C [392°F])
T	-250 to 300	-400 to 550	0.1% or $\pm 0.5^{\circ}\text{C}$ (0.9°F) (above -150°C [-238°F])
RTD	Maximum Range °C	Maximum Range °F	Accuracy (% of reading)
PT100	-200 to 600	-325 to 1100	0.1% or $\pm 0.5^{\circ}\text{C}$ (0.9°F)

Relays

Number of relays

1 as standard, 2 optional, (1 Module)

Type and rating

Relay type	Selectable NO/NC	
Voltage	250V AC	30V DC
Current	5A AC	5A DC
Loading (non-inductive)	1250VA	150W

2-Wire transmitter power supply

Number

2 isolated supplies

Voltage

24V DC nominal

Drive

22mA (each supply)

Ethernet Module

Physical medium

10BaseT

Protocols

TCP/IP, FTP (server), HTTP, SMTP, Modbus TCP (Client + Server)

FTP server functions

Directory selection & listing

File upload/download

4 independently configurable users with full or read-only access

Web server functions

Operator screen monitoring/selection. Remote monitoring of recording channels, analog/digital signals, alarms, totalizers and archiving.

Totalizer (optional)

Number

2 per recording channel, 10-digit totals

Type

Analog or digital

Statistical calculations

Average, maximum, minimum (for analog signals)

EMC

Emissions & immunity

Meets requirements of IEC61326 for an Industrial Environment

Electrical

Power supply type

Universal AC/DC

Supply ranges

85V min. to 265V max. AC 50/60Hz

9V to 36V DC (optional)

Power consumption

35VA max., 10W max.

Power interruption protection

No effect for interrupts of up to 20ms

Safety

General safety

EN61010-1

Overvoltage Class III on mains, Class II on inputs and outputs

Pollution category 2

CSA 1010

UL 1010

Isolation

500V DC to earth (ground)

Environmental

Operating temperature range

0 to 50°C (32 to 122°F)

Operating humidity range

5 to 95%RH (non-condensing)

Storage temperature range

-20 to 70°C (-4 to 174°F)

Enclosure sealing

IP66 and NEMA4X

Physical

Size

144mm (5.7in.) x 144mm (5.7in.) x 84mm (3.3 in.)

Weight

1.0kg (2.2 lb) approx. (unpacked)

Panel cutout

138mm (5.43 in.) x 138mm (5.43 in.) x 67mm (2.7 in.) behind panel

Case material

Glass-filled polycarbonate

Operator keypad

Tactile membrane keys

No. of keys

6

160002 Issue 2

Appendix A – Signal Sources

Source Name	Description
Analog Sources	
Analog I/P A1 to D1	Analog input values (from Analog input module). Available only if an analog input module is fitted in the relevant position.
Comms AIN 1 to 24	Analog input values. Received via the Modbus serial communications link – see Table B.14 on page 52.
Stats 1.1 to 1.4 max Stats 2.1 to 2.4 max	Maximum Statistics Input Value. Value since the totalizer on a given channel last wrap or reset. Available only if the totalizer option is enabled, only on analog channels and only if the relevant totalizer is enabled in the Configuration level.
Stats 1.1 to 1.4 min Stats 2.1 to 2.4 min	Minimum Statistics Input Value. Value since the totalizer on a given channel last wrap or reset. Available only if the totalizer option is enabled, only on analog channels and only if the relevant totalizer is enabled during configuration.
Stats 1.1 to 1.4 avg Stats 2.1 to 2.4 avg	Average Statistics Input Value. Value since the totalizer on a given channel last wrap or reset. Available only if the totalizer option is enabled, only on analog channels and only if the relevant totalizer is enabled during configuration.
Error States	
AIN A1 to D1 Fail State	Analog Input Failure.
Comms AIN 1 to 6 Fail State	Active when the signal detected at the analog input is outside the 'Fault Detect Level' specified during configuration.
Stats 1.1 to 1.4 fail Stats 2.1 to 2.4 fail	Totalizer Input Value Failure. Activated when the totalizer fails, cleared when the totalizer wraps or is reset. Available only if the totalizer option is enabled, only on analog channels and only if the relevant totalizer is enabled during configuration.
Archive media not present	Active when the removable archive media is not present.
Too many files on arc media	Active when there are approximately 300 files on the removable archive media.
Archive 100% full	Active when the removable archive media is 100% full
Archive 80% full	Active when the removable archive media is 80% full.
Arc media present	Active when the removable archive media is present.
Archive on-line	Active when archiving is in progress.

Table A.1 Signal Sources

Source Name	Description
Digital Input States	
Digital I/P A1 to D1	Digital Input States. Digital signals received from analog input modules fitted at module positions A to D if input 'Type' is set to 'Volt free digital input' during configuration. Available only if the module is fitted.
Comms Dig I/P 1 to 24	Digital Input States. Digital signals received via Modbus serial link – see Table B.14 on page 52.
Alarm state 1.1A to 2.4D	Alarm States. Available only if the relevant alarm is enabled during configuration.
Alarm ack state 1.1A to 2.4D	Alarm Acknowledge States. Available only if the relevant alarm is enabled during configuration. Acknowledged alarm = 0; Unacknowledged alarm = 1. Process, Latch and Annunciator alarms only.
Alarm group 1 to 12	Alarm Groups. Available only if any alarms are enabled during configuration. Active only if any of the alarms assigned to a group are active.
Any Alarm	Available only if there is at least one alarm enabled during configuration. Active only if any of the enabled alarms are active.
New Alarm	Available only as a source for e-mail triggers. Causes an e-mail to be generated if any alarm becomes active.
Real time alarm 1 to 4	Real Time Alarm States. Available only if the relevant alarm is enabled during configuration.
Run state 1.1 to 2.4	Totalizer Run States. Active while totalizer is running. Available only if the relevant totalizer is enabled in the configuration level.
Wrap pulse 1.1 to 2.4	Totalizer Wrap Pulse. Available only if the totalizer option is enabled and the relevant totalizer is enabled during configuration. If 'Wrap Enable' set to 'On' – active for 1 second when the predetermined count has been reached. If 'Wrap Enable' set to 'Off' – active when the predetermined count is been reached and remains active until the totalizer is reset
1st Stage O/P 1.1 to 2.4	Totalizer First Stage Output (Intermediate Count). Active for 1 second when the intermediate count has been reached. Available only if the totalizer option is enabled and the relevant totalizer is enabled during configuration.
Count pulse 1.1 to 2.4	Totalizer Count Pulse. Active for 100ms each time the totalizer updates by one whole count. E.g. if two decimal places are set, a pulse is generated when the totalizer value increments from 0.99 to 1.00 or 1.99 to 2.00

Table A.1 Signal Sources (continued)

Appendix B – ModbusTCP Guide

B.1 Introduction

The instrument can be configured to act as either a ModbusTCP client or server.

If configured as a client the recorder collects data from ModbusTCP servers (or RTUs via a gateway) into its Comms Analog and Comms Digital Channels.

If configured as a server the recorder responds to Modbus queries transferred via the ModbusTCP protocol for the registers described in this appendix.

B.2 Modbus Commands Supported

The following Modbus commands are supported:

- 01 Read Coil Status – reads the on/off status of 16 consecutive digital states, starting at a specified address. The instrument returns zeros for points which do not contain defined data.
- 03 Read Holding Registers – reads 8 consecutive analog values, starting from a specified address. The instrument returns zeros for registers which do not contain defined data.
- 05 Force Single Coil – Sets the value of a single coil (digital signal) at the specified address. The data value must be FF00Hex to set the signal ON and zero to turn it OFF. The instrument returns an exception response if the register is not currently writable.
- 06 Preset Single Register – Sets the value of a single register (analog value) at the specified address. The instrument returns an exception response if the register is not currently writable. Limits defined in configuration are applied to the value before storage.
- 15 Force Multiple Coils – The instrument carries out updates that are valid and returns an exception response if any of the coils are not currently writable.
- 16 Preset Multiple Registers – The instrument carries out updates that are valid and generates an exception response if any of the registers are not currently writable.

Note. Negative numbers are represented in '2's complement' format, for example, 1000 = 03E8 (Hex), -1000 = FC18 (Hex)

B.3 Modbus Exception Responses – Table B.1

If the instrument detects one of the errors shown in Table B.1 while receiving a message from the host system, it replies with a response message consisting of the instrument's Modbus address, the function code, the error code and the error check fields.

Code	Name	Definition
01	Illegal Function	The message function received is not an allowable action
02	Illegal Data Address	The address reference in the data field is not an allowable address
03	Illegal Data Value	The value referenced in the data field is not allowable in the addressed slave
07	Negative Acknowledgement	Received message errorb
08	Memory Parity Error	Parity check indicates an error in one or more of the characters received

Table B.1 Modbus Exception Responses

B.4 Operating Mode Modbus Coils – Tables B.2 to B.10

Tables B.2 to B.10 detail the contents of each Modbus coil. Each coil is assigned a register that can have one of two values: 0000 and 0001.

Read Only: 0 = Input OK, 1 = Input Failed	
Analog Input	Modbus Coil
A1	0001
B1	0002
C1	0003
D1	0004

Table B.2 Analog Input Fail States

	Alarm Active/ Inactive	Alarm Acknowledged
Read Access	0 = Alarm inactive 1 = Alarm active	0 = Acknowledged or inactive 1 = Active and unacknowledged
Write Access	None	0 = No effect 1 = Acknowledge
Alarm	Modbus Coil	Modbus Coil
1.1A	0051	0101
1.1B	0052	0102
1.1C	0053	0103
1.1D	0054	0104
1.2A	0055	0105
1.2B	0056	0106
1.2C	0057	0107
1.2D	0058	0108
1.3A	0059	0109
1.3B	0060	0110
1.3C	0061	0111
1.3D	0062	0112
1.4A	0063	0113
1.4B	0064	0114
1.4C	0065	0115
1.4D	0066	0116

Table B.3 Alarm States

	Alarm Active/ Inactive	Alarm Acknowledged
Read Access	0 = Alarm inactive 1 = Alarm active	0 = Acknowledged or inactive 1 = Active and unacknowledged
Write Access	None	0 = No effect 1 = Acknowledge
Alarm	Modbus Coil	Modbus Coil
2.1A	0067	0117
2.1B	0068	0118
2.1C	0069	0119
2.1D	0070	0120
2.2A	0071	0121
2.2B	0072	0122
2.2C	0073	0123
2.2D	0074	0124
2.3A	0075	0125
2.3B	0076	0126
2.3C	0077	0127
2.3D	0078	0128
2.4A	0079	0129
2.4B	0080	0130
2.4C	0081	0131
2.4D	0082	0132

		Read: Always returns '0' Write: 1 = Activate
Title	Coil Number	
Operator Message 1	0151	
Operator Message 2	0152	
Operator Message 3	0153	
Operator Message 4	0154	
Operator Message 5	0155	
Operator Message 6	0156	
Operator Message 7	0157	
Operator Message 8	0158	
Operator Message 9	0159	
Operator Message 10	0160	
Operator Message 11	0161	
Operator Message 12	0162	

		Read: Always returns '0' Write: 1 = Activate
Title	Coil Number	
Operator Message 13	0163	
Operator Message 14	0164	
Operator Message 15	0165	
Operator Message 16	0166	
Operator Message 17	0167	
Operator Message 18	0168	
Operator Message 19	0169	
Operator Message 20	0170	
Operator Message 21	0171	
Operator Message 22	0172	
Operator Message 23	0173	
Operator Message 24	0174	
Reserved	0175 to 0180	

Table B.4 Operator Messages

Title	Coil Number	Read	Write
Assign to Group 1	0181	0 = Remote operator message not assigned to group	0 = Unassign remote operator message from group
Assign to Group 2	0182	1 = Remote operator message assigned to group	1 = Assign remote operator message to group
Activate Remote Operator Message	0183	Always reads as 0	0 = No effect 1 = Activate

Table B.5 Remote Operator Messages

		Modbus Registers				
		Stop/Go	Reset	Wrap Pulse	1st Stage Pulse	Flowrate Failure
Read Access	0 = Stopped 1 = Running	0 = >1s* 1 = <1s*	0 = Inactive 1 = Active	0 = Inactive 1 = Active	0 = Inactive 1 = Active	0 = Inactive 1 = Active
Write Access	0 = Stop 1 = Start	1 = Reset				
Totalizer	Modbus Coil	Modbus Coil	Modbus Coil	Modbus Coil	Modbus Coil	Modbus Coil
1.1A	0351	0401	0451	0501	0551	
1.1B	0352	0402	0452	0502	0552	
1.2A	0353	0403	0453	0503	0553	
1.2B	0354	0404	0454	0504	0554	
1.3A	0355	0405	0455	0505	0555	
1.3B	0356	0406	0456	0506	0556	
1.4A	0357	0407	0457	0507	0557	
1.4B	0358	0408	0458	0508	0558	
2.1A	0359	0409	0459	0509	0559	
2.1B	0360	0410	0460	0510	0560	
2.2A	0361	0411	0461	0511	0561	
2.2B	0362	0412	0462	0512	0562	
2.3A	0363	0413	0463	0513	0563	
2.3B	0364	0414	0464	0514	0564	
2.4A	0365	0415	0465	0515	0565	
2.4B	0366	0416	0466	0516	0566	

* Time since last reset

Table B.6 Totalizer Digital Signals

Read Only: 0 = All alarms inactive 1 = At least 1 alarm active	
Title	Coil Number
Any Alarm	0750

Table B.7 Any Alarm

Read Only: 0 = Alarm group inactive 1 = Alarm group active	
Title	Coil Number
Alarm Group 1	0751
Alarm Group 2	0752
Alarm Group 3	0753
Alarm Group 4	0754
Alarm Group 5	0755
Alarm Group 6	0756

Read Only: 0 = Alarm group inactive 1 = Alarm group active	
Title	Coil Number
Alarm Group 7	0757
Alarm Group 8	0758
Alarm Group 9	0759
Alarm Group 10	0760
Alarm Group 11	0761
Alarm Group 12	0762

Table B.8 Alarm Groups

Read Only: 0 = Real time alarm inactive
 1 = Real time alarm active

Title	Coil Number
Real Time Alarm 1	0851
Real Time Alarm 2	0852
Real Time Alarm 3	0853
Real Time Alarm 4	0854

Table B.9 Real Time Alarms

Signal		Channel							
		1.1	1.2	1.3	1.4	2.1	2.2	2.3	2.4
Channel Fail Status	Read Only	1001	1031	1061	1091	1121	1151	1181	1211
Alarm A	Read Only	1002	1032	1062	1092	1122	1152	1182	1212
Alarm B	Read Only	1003	1033	1063	1093	1123	1153	1183	1213
Alarm C	Read Only	1004	1034	1064	1094	1124	1154	1184	1214
Alarm D	Read Only	1005	1035	1065	1095	1125	1155	1185	1215
Alarm A Acknowledge	Read/Write	1006	1036	1066	1096	1126	1156	1186	1216
Alarm B Acknowledge	Read/Write	1007	1037	1067	1097	1127	1157	1187	1217
Alarm C Acknowledge	Read/Write	1008	1038	1068	1098	1128	1158	1188	1218
Alarm D Acknowledge	Read/Write	1009	1039	1069	1099	1129	1159	1189	1219
Totalizer A Stop/Go	Read/Write	1010	1040	1070	1100	1130	1160	1190	1220
Totalizer A Reset	Read/Write	1011	1041	1071	1101	1131	1161	1191	1221
Totalizer A Wrap	Read Only	1012	1042	1072	1102	1132	1162	1192	1222
Totalizer A First Stage	Read Only	1013	1043	1073	1103	1133	1163	1193	1223
Totalizer A Flowrate Fail	Read Only	1014	1044	1074	1104	1134	1164	1194	1224
Totalizer B Stop/Go	Read/Write	1015	1045	1075	1105	1135	1165	1195	1225
Totalizer B Reset	Read/Write	1016	1046	1076	1106	1136	1166	1196	1226
Totalizer B Wrap	Read Only	1017	1047	1077	1107	1137	1167	1197	1227
Totalizer B First Stage	Read Only	1018	1048	1078	1108	1138	1168	1198	1228
Totalizer B Flowrate Fail	Read Only	1019	1049	1079	1109	1139	1169	1199	1229
Channel Type	Read Only	1020	1050	1080	1110	1140	1170	1200	1230
Digital Value	Read Only	1021	1051	1081	1111	1141	1171	1201	1231

Table B.10 Channel Digital Signals

B.5 Operating Mode ModbusTCP Registers – Tables B.11 to B.13

Tables B.11 to B.13 detail the contents of the ModbusTCP registers accessible while the instrument is in the operating mode.

Two data types are used:

- 32-bit single precision floating point data in IEEE format
- 64-bit double precision floating point data in IEEE format

Note.

- When writing to a parameter that occupies more than one register position then all registers relating to that parameter **MUST** be written to as part of a multiple register write. If this is not achieved a NAK exception response is issued. Individual registers can be read without causing an exception response.
- When accessing a parameter that occupies more than one register position, the lowest numbered register contains the most significant data.

Analog Input	Modbus Register
A1	0001 and 0002
B1	0003 and 0004
C1	0005 and 0006
D1	0007 and 0008

Read Only, single precision IEEE floating point number

Table B.11 Analog Inputs

Alarm	Trip Point Registers	Alarm	Trip Point Registers
1.1A	0101 and 0102	2.1A	0133 and 0134
1.1B	0103 and 0104	2.1B	0135 and 0136
1.1C	0105 and 0106	2.1C	0137 and 0138
1.1D	0107 and 0108	2.1D	0139 and 0140
1.2A	0109 and 0110	2.2A	0141 and 0142
1.2B	0111 and 0112	2.2B	0143 and 0144
1.2C	0113 and 0114	2.2C	0145 and 0146
1.2D	0115 and 0116	2.2D	0147 and 0148
1.3A	0117 and 0118	2.3A	0149 and 0150
1.3B	0119 and 0120	2.3B	0151 and 0152
1.3C	0121 and 0122	2.3C	0153 and 0154
1.3D	0123 and 0124	2.3D	0155 and 0156
1.4A	0125 and 0126	2.4A	0157 and 0158
1.4B	0127 and 0128	2.4B	0159 and 0160
1.4C	0129 and 0130	2.4C	0161 and 0162
1.4D	0131 and 0132	2.4D	0163 and 0164

Table B.12 Alarm Trip Levels

	Current Batch				Previous Batch			
	IEEE	IEEE	IEEE	Double Precision Floating Point	IEEE	IEEE	IEEE	Double Precision Floating Point
Totalizer	Maximum Flowrate	Minimum Flowrate	Average Flowrate	Batch Total	Maximum Flowrate	Minimum Flowrate	Average Flowrate	Batch Total
1.1A	0251 and 0252	0301 and 0302	0351 and 0352	0401 to 0404	0551 and 0552	0601 and 0602	0651 and 0652	0701 to 0704
1.1B	0253 and 0254	0303 and 0304	0353 and 0354	0405 to 0408	0553 and 0554	0603 and 0604	0653 and 0654	0705 to 0708
1.2A	0255 and 0256	0305 and 0306	0355 and 0356	0409 to 0412	0555 and 0556	0605 and 0606	0655 and 0656	0409 to 0412
1.2B	0257 and 0258	0307 and 0308	0357 and 0358	0413 to 0416	0557 and 0558	0607 and 0608	0657 and 0658	0713 to 0716
1.3A	0259 and 0260	0309 and 0310	0359 and 0360	0417 to 0420	0559 and 0560	0609 and 0610	0659 and 0660	0717 to 0720
1.3B	0261 and 0262	0311 and 0312	0361 and 0362	0421 to 0424	0561 and 0562	0611 and 0612	0661 and 0662	0721 to 0724
1.4A	0263 and 0264	0313 and 0314	0363 and 0364	0425 to 0428	0563 and 0564	0613 and 0614	0663 and 0664	0725 to 0728
1.4B	0265 and 0266	0315 and 0316	0365 and 0366	0429 to 0432	0565 and 0566	0615 and 0616	0665 and 0666	0729 to 0732
2.1A	0267 and 0268	0317 and 0318	0367 and 0368	0433 to 0436	0567 and 0568	0617 and 0618	0667 and 0668	0733 to 0736
2.1B	0269 and 0270	0319 and 0320	0369 and 0370	0437 to 0440	0569 and 0570	0619 and 0620	669 and 0670	0737 to 0740
2.2A	0271 and 0272	0321 and 0322	0371 and 0372	0441 to 0444	0571 and 0572	0621 and 0622	0671 and 0672	0441 to 0444
2.2B	0273 and 0274	0323 and 0324	0373 and 0374	0445 to 0448	0573 and 0574	0623 and 0624	0673 and 0674	0745 to 0748
2.3A	0275 and 0276	0325 and 0326	0375 and 0376	0449 to 0452	0575 and 0576	0625 and 0626	0675 and 0676	0749 to 0752
2.3B	0277 and 0278	0327 and 0328	0377 and 0378	0453 to 0456	0577 and 0578	0627 and 0628	0677 and 0678	0753 to 0756
2.4A	0279 and 0280	0329 and 0330	0379 and 0380	0457 to 0460	0579 and 0580	0629 and 0630	0679 and 0680	0757 to 0760
2.4B	0281 and 0282	0331 and 0332	0381 and 0382	0461 to 0464	0581 and 0582	0631 and 0632	0681 and 0682	0761 to 0764

Table B.13 Totalizer Totals

B.6 Communications – Analog and Digital Inputs

	Comms. Digital Inputs	Comms. Analog Inputs Failure	Comms. Analog Inputs		Comms. Digital Inputs	Comms. Analog Inputs Failure	Comms. Analog Inputs
	Read/Write: 0 = Inactive 1 = Active		Floating point (-999 to 9999)		Read/Write: 0 = Inactive 1 = Active		Floating point (-999 to 9999)
Input Number	Coil Number	Coil Number	Registers	Input Number	Coil Number	Coil Number	Registers
1	0601	0651	0851 and 0852	13	0613	0663	0855 and 0856
2	0602	0652	0853 and 0854	14	0614	0664	0857 and 0858
3	0603	0653	0855 and 0856	15	0615	0665	0859 and 0860
4	0604	0654	0857 and 0858	16	0616	0666	0861 and 0862
5	0605	0655	0859 and 0860	17	0617	0667	0863 and 0864
6	0606	0656	0861 and 0862	18	0618	0668	0865 and 0866
7	0607	0657	0863 and 0864	19	0619	0669	0867 and 0868
8	0608	0658	0865 and 0866	20	0620	0670	0869 and 0870
9	0609	0659	0867 and 0868	21	0621	0671	0871 and 0872
10	0610	0660	0869 and 0870	22	0622	0672	0873 and 0874
11	0611	0661	0871 and 0872	23	0623	0673	0875 and 0876
12	0612	0662	0873 and 0874	24	0624	0674	0877 and 0878
				Reserved	0625 to 0650	0675 to 0700	0899 to 1000

Table B.14 Modbus Inputs

Signal		Channel								
		1.1	1.2	1.3	1.4	2.1	2.2	2.3	2.4	
Channel Input	Read Only	1001 and 1002	1051 and 1052	1101 and 1102	1151 and 1152	1201 and 1202	1251 and 1252	1301 and 1302	1351 and 1352	
Alarm A Trip	Read/Write	1003 and 1004	1053 and 1054	1103 and 1104	1153 and 1154	1203 and 1204	1253 and 1254	1303 and 1304	1353 and 1354	
Alarm B Trip	Read/Write	1005 and 1006	1055 and 1056	1105 and 1106	1155 and 1156	1205 and 1206	1255 and 1256	1305 and 1306	1355 and 1356	
Alarm C Trip	Read/Write	1007 and 1008	1057 and 1058	1107 and 1108	1157 and 1158	1207 and 1208	1257 and 1258	1307 and 1308	1357 and 1358	
Alarm D Trip	Read/Write	1009 and 1010	1059 and 1060	1109 and 1110	1159 and 1160	1209 and 1210	1259 and 1260	1309 and 1310	1359 and 1360	
Current Batch	Totalizer A Max	Read Only	1011 and 1012	1061 and 1062	1111 and 1112	1161 and 1162	1211 and 1212	1261 and 1262	1311 and 1312	1361 and 1362
	Totalizer A Min	Read Only	1013 and 1014	1063 and 1064	1113 and 1114	1163 and 1164	1213 and 1214	1263 and 1264	1313 and 1314	1363 and 1364
	Totalizer A Average	Read Only	1015 and 1016	1065 and 1066	1115 and 1116	1165 and 1166	1215 and 1216	1265 and 1266	1315 and 1316	1365 and 1366
	Totalizer A Total	Read Only	1017 to 1020	1067 to 1070	1117 to 1120	1167 to 1170	1217 to 1220	1267 to 1270	1317 to 1320	1367 to 1370
Previous Batch	Totalizer A Max	Read Only	1021 and 1022	1071 and 1072	1121 and 1122	1171 and 1172	1221 and 1222	1271 and 1272	1321 and 1322	1371 and 1372
	Totalizer A Min	Read Only	1023 and 1024	1073 and 1074	1123 and 1124	1173 and 1174	1223 and 1224	1273 and 1274	1323 and 1324	1373 and 1374
	Totalizer A Average	Read Only	1025 and 1026	1075 and 1076	1125 and 1126	1175 and 1176	1225 and 1226	1275 and 1276	1325 and 1326	1375 and 1376
	Totalizer A Total	Read Only	1027 to 1030	1077 to 1080	1127 to 1130	1177 to 1180	1227 to 1230	1277 to 1280	1327 to 1330	1377 to 1380
Current Batch	Totalizer B Max	Read Only	1031 and 1032	1081 and 1082	1131 and 1132	1181 and 1182	1231 and 1232	1281 and 1282	1331 and 1332	1381 and 1382
	Totalizer B Min	Read Only	1033 and 1034	1083 and 1084	1133 and 1134	1183 and 1184	1233 and 1234	1283 and 1284	1333 and 1334	1383 and 1384
	Totalizer B Average	Read Only	1035 and 1036	1085 and 1086	1135 and 1136	1185 and 1186	1235 and 1236	1285 and 1286	1335 and 1336	1385 and 1386
	Totalizer B Total	Read Only	1037 to 1040	1087 to 1090	1137 to 1140	1187 to 1190	1237 to 1240	1287 to 1290	1337 to 1340	1387 to 1390
Previous Batch	Totalizer B Max	Read Only	1041 and 1042	1091 and 1092	1141 and 1142	1191 and 1192	1241 and 1242	1291 and 1292	1341 and 1342	1391 and 1392
	Totalizer B Min	Read Only	1043 and 1044	1093 and 1094	1143 and 1144	1193 and 1194	1243 and 1244	1293 and 1294	1343 and 1344	1393 and 1394
	Totalizer B Average	Read Only	1045 and 1046	1095 and 1096	1145 and 1146	1195 and 1196	1245 and 1246	1295 and 1296	1345 and 1346	1395 and 1396
	Totalizer B Total	Read Only	1047 to 1050	1097 to 1100	1147 to 1150	1197 to 1200	1247 to 1250	1297 to 1300	1347 to 1350	1397 to 1400

Table B.15 Channel Data

Read/ Write: ASCII Character Code – see Table B.17					
Input	Register Number	Input	Register Number	Input	Register Number
Character 1	0951	Character 8	0958	Character 15	0965
Character 2	0952	Character 9	0959	Character 16	0966
Character 3	0953	Character 10	0960	Character 17	0967
Character 4	0954	Character 11	0961	Character 18	0968
Character 5	0955	Character 12	0962	Character 19	0969
Character 6	0956	Character 13	0963	Character 20	0970
Character 7	0957	Character 14	0964		

Table B.16 Remote Operator Messages

Hex	Dec	Char	Hex	Dec	Char	Hex	Dec	Char	Hex	Dec	Char	Hex	Dec	Char
20	32	Space	34	52	4	47	71	G	5A	90	Z	6D	109	m
21	33	!	35	53	5	48	72	H	5B	91	[6E	110	n
22	34	"	36	54	6	49	73	I	5C	92	\	6F	111	o
23	35	#	37	55	7	4A	74	J	5D	93]	70	112	p
24	36	\$	38	56	8	4B	75	K	5E	94	^	71	113	q
25	37	%	39	57	9	4C	76	L	5F	95	_	72	114	r
26	38	&	3A	58	:	4D	77	M	60	96	N/A	73	115	s
27	39	`	3B	59	;	4E	78	N	61	97	a	74	116	t
28	40	(3C	60	<	4F	79	O	62	98	b	75	117	u
29	41)	3D	61	=	50	80	P	63	99	c	76	118	v
2A	42	*	3E	62	>	51	81	Q	64	100	d	77	119	w
2B	43	+	3F	63	?	52	82	R	65	101	e	78	120	x
2C	44	N/A	40	64	@	53	83	S	66	102	f	79	121	y
2D	45	-	41	65	A	54	84	T	67	103	g	7A	122	z
2E	46	.	42	66	B	55	85	U	68	104	h	7B	123	{
2F	47	/	43	67	C	56	86	V	69	105	i	7C	124	
30	48	0	44	68	D	57	87	W	6A	106	j	7D	125	}
31	49	1	45	69	E	58	88	X	6B	107	k	7E	126	~
32	50	2	46	70	F	59	89	Y	6C	108	l	7F	127	N/A
33	51	3												

Hex	Dec	Char
A3	163	£
B0	176	°
B2	178	∑
B3	179	∏
B5	181	μ
3A9	937	Ω

Note. Character codes 2C, 60 and 7F Hex (44, 96 and 127 Dec) are not supported

Table B.17 ASCII Character Set for Remote Operator Messages

Appendix C – Storage Capacity

C.1 Internal Storage Capacity – Table C.1

Approximate duration calculated for continuous recording of 4 channels of analog data (for 8 channels divide by 2; for 2 channels multiply by 2 etc.).

Sample Rate	1 second	10 seconds	40 seconds	60 seconds	120 seconds	480 seconds
8Mb internal Flash memory	6 days	2 months	7.5 months	1 year	2 years	7 years

Table C.1 Internal Storage Capacity

C.2 External Storage Capacity – Tables C.2 and C.3

Approximate duration calculated for continuous recording of 4 channels of analog data (for 8 channels divide by 2; for 2 channels multiply by 2 etc.).

Sample Rate	SD Card Size			
	128Mb	256Mb	512Mb	1Gb
1.0 second	20 days	40 days	2.5 months	5 months
10.0 seconds	6 months	12 months	2 years	4 years

Table C.2 External (Archive) Storage Capacity – Text Formatted Archive Files

Sample Rate	SD Card Size			
	128Mb	256Mb	512Mb	1Gb
1.0 second	3 months	6 months	12 months	2 years
10.0 seconds	2.5 years	5 years	10 years	20 years

Table C.3 External (Archive) Storage Capacity – Binary Formatted Archive Files

Appendix D – Units

Unit	Description
deg F	Degrees Fahrenheit
Kelvin	Degrees Kelvin
%RH	% Relative Humidity
%	%
ppm	parts per million
ppb	parts per billion
pH	potential Hydrogen
l/d	liters per day
l/h	liters per hour
l/m	liters per minute
l/s	liters per second
MI/d	megaliters per day
MI/h	megaliters per hour
MI/m	megaliters per minute
MI/s	megaliters per second
gal/d (UK)	imperial gallons per day
gal/h (UK)	imperial gallons per hour
gal/m (UK)	imperial gallons per minute
gal/s (UK)	imperial gallons per second
Mgal/d (UK)	imperial mega gallons per day
gal/d (US)	US gallons per day
gal/h (US)	US gallons per hour
gal/m (US)	US gallons per minute
gal/s (US)	US gallons per second
Mgal/d (US)	US mega gallons
m3/d	cubic meters per day
m3/h	cubic meters per hour
m3/m	cubic meters per minute
m3/s	cubic meters per second
ft3/d	cubic feet per day
ft3/h	cubic feet per hour

Unit	Description
lb/d	pounds per day
lb/h	pounds per hour
lb/m	pounds per minute
lb/s	pounds per second
ton/d	imperial tons per day
ton/h	imperial tons per hour
ton/m	imperial tons per minute
ton/s	imperial tons per second
ug/kg	micrograms per kilogram
mg/kg	milligrams per kilogram
mbar	millibar
bar	bar
m WG	meters water gauge
Hz	hertz
kHz	kilohertz
% sat	% saturation
%O2	% oxygen
%N2	% nitrogen
%HCl	% hydrochloric acid
NTU	nephelometric turbidity units
FTU	formazine turbidity units
%OBS	% obscuration
g/l	grams per liter
g/h	grams per hour
g/d	grams per day
ml/m	milliliters per minute
ml/h	milliliters per hour
%dO2	% dissolved oxygen
uV	microvolts
mV	millivolts
MV	megavolts

Table D.1 Engineering Units

Unit	Description
ft ³ /m	cubic feet per minute
ft ³ /s	cubic feet per second
SCFM	standard cubic feet per minute
kg/d	kilograms per day
kg/h	kilograms per hour
kg/m	kilograms per minute
kg/s	kilograms per second
T/d	metric tonnes per day
T/h	metric tonnes per hour
T/m	metric tonnes per minute
T/s	metric tonnes per second

Unit	Description
A	amps
mho	conductance
S	Siemens
uS/cm	microSiemens per centimeter
mS/cm	milliSiemens per centimeter
uS/m	microSiemens per meter
mS/m	milliSiemens per meter
Feet	imperial feet
Inches	imperial inches
Custom	user defined units

Table D.1 Engineering Units (continued)

Unit	Description
l	liters
ml	milliliters
kl	kiloliters
MI	megaliters
m	meters
gal (UK)	imperial gallons
g x 10 (UK)	imperial gallons x 10
g x100 (UK)	imperial gallons x 100
kgal (UK)	imperial kilo gallons
Mgal (UK)	imperial mega gallons
gal (US)	us gallons
g x 10 (US)	us gallons x 10
g x100 (US)	us gallons x 100
kgal (US)	us kilo gallons
Mgal (US)	us mega gallons

Unit	Description
m ³	cubic meters
km ³	kilo cubic meters
Mm ³	mega cubic meters
CUMEC	cubic meter of water per second
kg	kilograms
T	tons
kT	kilotons
lb	pounds
ton	imperial tons
btu	british thermal units
ft ³	cubic feet
kft ³	kilo cubic feet
Mft ³	mega cubic feet
AcreFt	volume of water, 1ft deep, covering an area of 1 acre
Custom	user defined units

Table D.2 Totalizer Units

Index

A	
Accessing the configuration level	26
C	
Configuration	
Data entry dialog boxes	30
Exiting configuration mode	31
Locating parameter settings	29
Overview	28
Configuration level security	24
D	
Displays and controls	19
E	
Electrical installation	
Cable entry	13
Cable glands	13
Cable screening connections	13
Connections	15
Analog/digital input connections	16
Ethernet cable routing	13
Knockout removal	13
Thermocouple compensating cable	17
End of life disposal	5
Engineering units	56
F	
Functional overview	3
I	
Installation	9
Environmental limits	7
Mounting dimensions	8
Pipe-mounting	11, 13
Siting	6
Wall-mounting	10
L	
Logging access	
Advanced security	22
Basic security	21

M

ModbusTCP 45
 Alarm groups 48
 Alarm states 46
 Alarm trip levels 50
 Analog input fail states 46
 Analog inputs 50
 Any alarm 48
 Channel data 53
 Channel digital signals 49
 Character set for remote operator messages 54
 Commands 45
 Exception responses 45
 Modbus inputs 52
 Operator messages 47
 Real time alarms 49
 Remote operator messages 47, 54
 Totalizer digital signals 48
 Totalizer totals 51

O

On-line help 18
Operator displays 20

P

Panel-mounting 9
Password entry 23

S

Setting the security switch 27
Signal sources 43
Specification 33 to 42
Storage capacity
 External 55
 Internal 55

T

Totalizer units 57

Notes

Client Warranty

Prior to installation, the equipment referred to in this manual must be stored in a clean, dry environment, in accordance with the Company's published specification.

Periodic checks must be made on the equipment's condition. In the event of a failure under warranty, the following documentation must be provided as substantiation:

1. A listing evidencing process operation and alarm logs at time of failure.
2. Copies of all storage, installation, operating and maintenance records relating to the alleged faulty unit.

Modbus™ is a registered trademark of the Modbus-IDA organization

Microsoft is a registered trademark of Microsoft Corporation in the United States and/or other countries

The Company's policy is one of continuous product improvement and the right is reserved to modify the information contained herein without notice.

Printed in the EU (07.06)

© CAMILLE BAUER 2006



CAMILLE BAUER AG

Aargauerstrasse 7
CH-5610 Wohlen
Switzerland
Tel: +41 56 618 21 11
Fax: +41 56 618 24 58
www.camillebauer.com