

Plug-in module SIRAX V 644

Programmable universal transmitter

for DC currents or voltages,
temperature sensors, remote sensors
or potentiometers

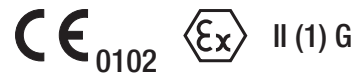

Application

The universal transmitter **SIRAX V 644** (Fig. 1) converts the input variable – a DC current or voltage, or a signal from a thermocouple, resistance thermometer, remote sensor or potentiometer – to a proportional analogue output signal.

The analogue output signal is either an impressed current or superimposed voltage which is processed by other devices for purposes of displaying, recording and/or regulating a constant.

A considerable number of measuring ranges including bipolar or spread ranges are available.

Input variable and measuring range are programmed with the aid of a PC and the corresponding software. Other parameters relating to specific input variable data, the analogue output signal, the transmission mode, the operating sense and the open-circuit sensor supervision can also be programmed.

The open-circuit sensor supervision is in operation when the SIRAX V 644 is used in conjunction with a thermocouple, resistance thermometer, remote sensor or potentiometer.

The transmitter fulfils all the important requirements and regulations concerning electromagnetic compatibility **EMC** and **Safe Isolation** (IEC 1010 resp. EN 61 010). It was developed and is manufactured and tested in strict accordance with the **quality assurance standard ISO 9001**.

An explosion-proof “Intrinsically safe” [Ex ia] IIC version rounds off this series of SIRAX V 644. Production QA is also certified according to guideline 94/9/EG.

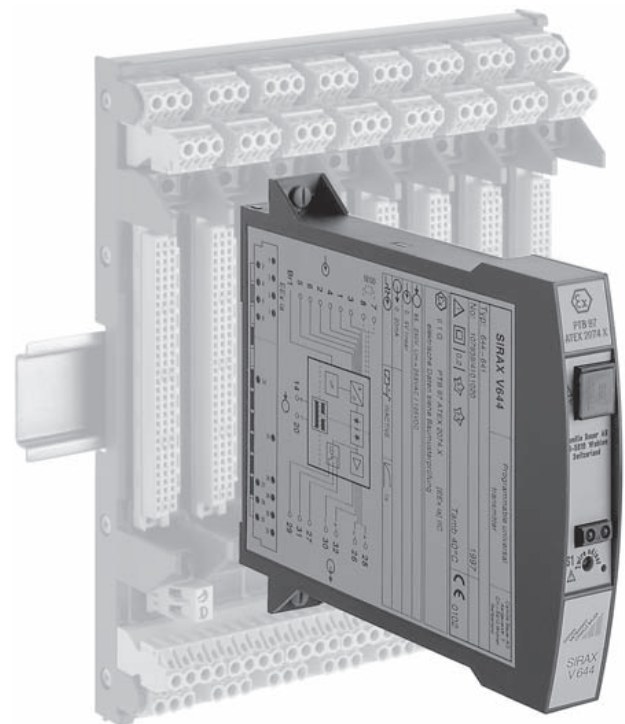

Fig. 1. Plug-in module SIRAX V 644 for plugging onto backplane BP 902.

Features / Benefits

- **Transmitter plugs onto backplane** (mechanically latched by fasteners), all electrical connections made to the backplane and not to the SIRAX V 644 / Thus no wiring when replacing devices
- **Input variable** (temperatures, variations of resistance, DC signals) and all measuring ranges programmed using PC / Simplifies project planning and engineering (the final measuring range can be determined during commissioning). Short delivery times and low stocking levels
- **Analogue output signal also programmed on the PC** (impressed current or superimposed voltage for all ranges between – 20 and + 20 mA DC resp. – 12 and + 15 V DC) / Universally applicable. Short delivery times and low stocking levels
- Electric insulation between measured variable, analogue output signal and power supply / Fulfills IEC 1010 resp. EN 61 010 Part 2
- AC/DC power supply / Universal
- Available in type of protection “Intrinsically safe” [Ex ia] IIC (see “Table 6: Data on explosion protection”)
- Ex devices directly programmable on site (with programming adapter Type PRKAB 600 PTB 97 ATEX 2082 U only)

Plug-in module SIRAX V 644

Programmable universal transmitter

- **Other programmable parameters: specific measured variable data** (e.g. two, three or four-wire connection for resistance thermometers, "internal" or "external" cold junction compensation of thermocouples etc.), **transmission mode** (special linearised characteristic or characteristic determined by a mathematical relationship, e.g. output signal = f (measured variable)), **operating sense** (output signal directly or inversely proportional to the measured variable) and **open-circuit sensor supervision** (output signal assumes fixed preset value between - 10 and + 110%, supplementary output contact signalling relay) / **Highly flexible solutions for measurement problems**
- **All programming operations by IBM XT, AT or compatible PC running the self-explanatory, menu-controlled programming software, if necessary, during operation / No ancillary hand-held terminals needed**
- **Digital measured variable data available at the programming interface / Simplifies commissioning, measured variable and signals can be viewed on PC in the field**
- **Standard software includes functional test program / No external simulator or signal injection necessary**
- **Self-monitoring function and continuously running test program / Automatic signalling of defects and device failure**

Terminals 4 and 6 are also input terminals and are used for measuring currents and for voltages which exceed ± 300 mV.

An extremely important component of the input stage is the EMC filter which protects the transmitter from interference or even destruction due to induced electromagnetic waves.

From the input stage, the measured variable (e.g. the voltage of a thermocouple) and the two auxiliary signals (cold junction compensation and the open-circuit sensor supervision) go to the multiplexer (4), which controlled by the micro-controller (6) applies them cyclically to the A/D converter (5).

The A/D converter operates according to the dual slope principle with an integration time of 20 ms at 50 Hz and a conversion time of approximately 38 ms per cycle. The internal resolution is 12 Bit regardless of measuring range.

The micro-controller relates the measured variable to the auxiliary signals and to the data which were loaded in the micro-controller's EEPROM via the programming connector (7) when the transmitter was configured. These settings determine the type of measured variable, the measuring range, the transmission mode (e.g. linearised temperature/thermocouple voltage relationship) and the operating sense (output signal directly or inversely proportional to the measured variable). The measured signal is then filtered again, but this time digitally to achieve the maximum possible immunity to interference. Finally the value of the measured variable for the output signal is computed. Apart from normal operation, the programming connector is also used to transfer measured variables on-line from the transmitter to the PC or vice versa. This is especially useful during commissioning and maintenance.

Depending on the measured variable and the input circuit, it can take 0.4 to 1.1 seconds before a valid signal arrives at the opto-coupler (8). The different processing times result from the fact that, for example, a temperature measurement with a four-wire resistance thermometer and open-circuit sensor supervision requires more measuring cycles than the straight forward measurement of a low voltage.

The main purpose of the opto-coupler is to provide electrical insulation between input and output. On the output side of the opto-coupler, the D/A converter (9) transforms the digital signal back to an analogue signal which is then amplified in the output stage (10) and split into two non-electrically isolated output channels. A powerful heavy-duty output is available at A1 and a less powerful output for a field display unit at A2. By a combination of programming and setting the 8 DIP switches in the output stage, the signals at A1 and A2 can be configured to be either a DC current or DC voltage (but both must be either one or the other). The signal A1 is available at connections 26 and 28 and A2 at connections 32 and 30.

If the micro-controller (6) detects an open-circuit measurement sensor, it firstly sets the two output signals A1 and A2 to a constant value. The latter can be programmed to adopt a preset value between - 10 and + 110% or to maintain the value it had at the instant the open-circuit was detected. In this state, the micro-controller also switches on the red LED (11) and causes the green LED

Principle of operation (Fig. 2)

The measured variable M is stepped down to a voltage between - 300 and + 300 mV in the input stage (1). The input stage includes potential dividers and shunts for this purpose. A constant reference current facilitates the measurement of resistance. Depending on the type of measurement, either one or more of the connections 1, 2, 3, 4 and 6 and the common ground connection 5 are used.

The constant reference current which is needed to convert a variation of resistance such as that of a resistance thermometer, remote sensor or potentiometer to a voltage signal is available at connection 3. The internal current source (2) automatically sets the reference current to either 60 or 380 μ A to suit the measuring range. The corresponding signal is applied to connection 1 and is used for resistance measurement.

Connection 2 is used for "active" sensors, i.e. thermocouples or other mV generators which inject a voltage between - 300 and + 300 mV. Small currents from the open-circuit sensor supervision (3) are superimposed on the signals at connections 1 and 2 in order to monitor the continuity of the measurement circuit. Connection 2 is also connected to the cold junction compensation element which is a Ni 100 resistor plugs onto backplane BP 902.

(12) to flash. Via the opto-coupler (8), it also excites the relay driver (13) which depending on configuration switches the relay (14) to its energized or de-energized state. The output contact is available at connections 27, 29 and 31. It is used by safety circuits. In addition to being able to program the relay to be either energized or de-energized, it can also be set to "relay de-energized". In this case, an open-circuit sensor is only signalled by the output signal being held constant, the red LED being switched on and the green LED flashing. The relay can also be configured to monitor the measured variable in relation to a programmable limit.

The normal state of the transmitter is signalled when the green LED (12) is continuously lit. It flashes should the measurement sensor become open-circuit and it also flashes, however, if the measured variable falls 10% below the start of the measuring range or rises 10% above its maximum value and during the first five seconds after the transmitter is switched on.

The push-button S1 is for automatically calibrating the leads of a two-wire resistance thermometer circuit. This is done by temporarily shorting the resistance sensor and pressing the button for at least three seconds. The lead resistance is then automatically measured and taken into account when evaluating the measure variable.

The power supply H is connected to connections 14 and 20 on the input block (15). The polarity is of no consequence, because the input voltage is chopped on the primary side of the power block (16) before being applied to a full-wave rectifier. Apart from the terminals, the input block (15) also contains an EMC filter which suppresses any electromagnetic interference superimposed on the power supply. The transformer block (17) provides the electrical insulation between the power supply and the other circuits and also derives two secondary voltages. One of these (5 V) is rectified and stabilised in (18) and then supplies the electronic circuits on the input side of the transmitter. The other AC from block (17) (-16 V / + 18 V) is rectified in (19) and used to supply the relay driver and the other components on the output side of the transmitter.

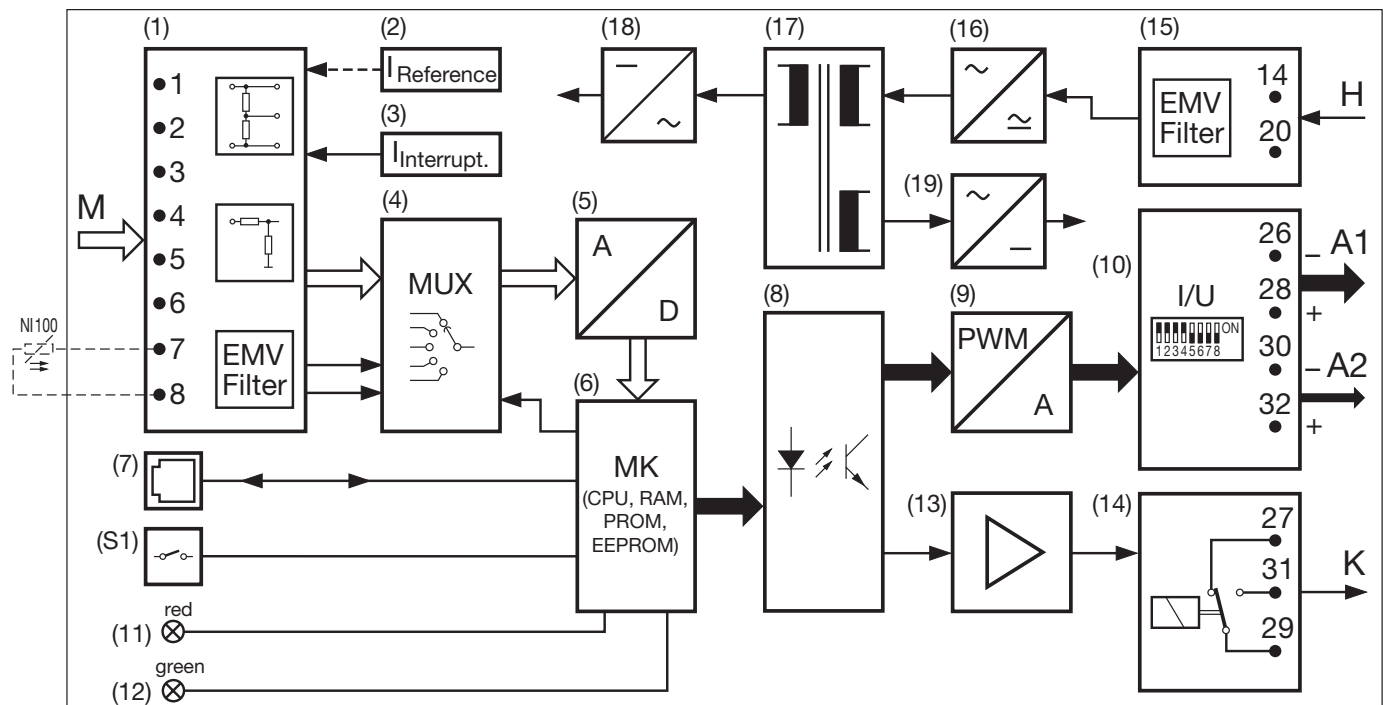

Fig. 2. Block diagram.

Plug-in module SIRAX V 644

Programmable universal transmitter

Programming (Figs. 3 and 4)

A PC with an RS 232 C interface (Windows 3.1x, 95, 98, NT or 2000), the programming cable PRKAB 600 and the configuration software VC 600 are required to program the transmitter. (Details of the programming cable and the software are to be found in the separate Data sheet: PRKAB 600 Le.)

The connections between "PC ↔ PRKAB 600 ↔ SIRAX V 644" can be seen from Fig. 3. The power supply must be applied to SIRAX V 644 before it can be programmed.

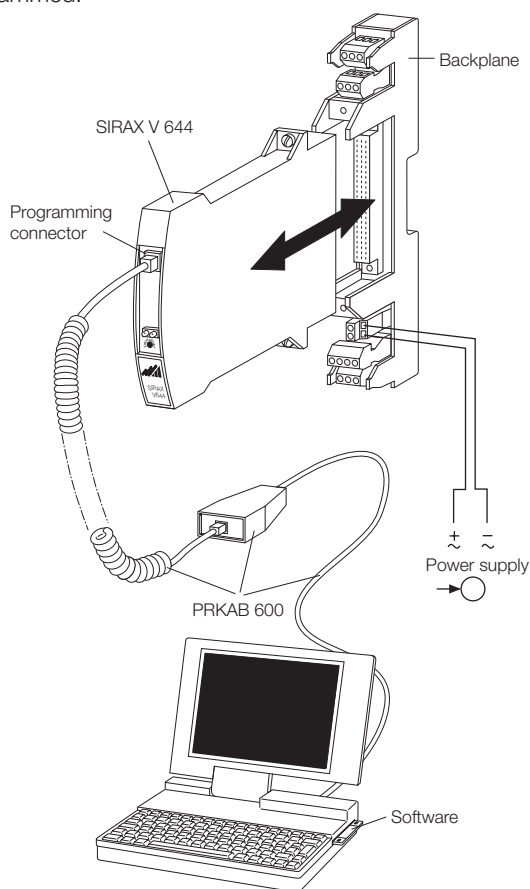

Fig. 3

The software VC 600 is supplied on a CD.

The programming cable PRKAB 600 adjusts the signal level and provides the electrical insulation between the PC and SIRAX V 644.

The programming cable PRKAB 600 is used for programming both standard and Ex versions.

Of the programmable details listed in section "Features/Benefits" **one** parameter – the **output signal** – has to be determined by PC programming as well as mechanical setting on the transmitter unit ...

... the output signal **range by PC**

... the **type** of output (current or voltage signal) has to be set **by DIP switch** (see Fig. 4).

The eight pole DIP switch is located on the PCB in the SIRAX V 644.

DIP switches	Type of output signal
	load-independent current
	load-independent voltage

Fig. 4

Technical data

Measuring input \rightarrow

Measured variable M

The measured variable M and the measuring range can be programmed

Table 1: Measured variables and measuring ranges

Measured variables	Measuring ranges		
	Limits	Min. span	Max. span
DC voltages			
direct input	$\pm 300 \text{ mV}^1$	2 mV	300 mV
via potential divider ²	$\pm 40 \text{ V}^1$	300 mV	40 V
DC currents			
low current ranges	$\pm 12 \text{ mA}^1$	0.08 mA	12 mA
high current ranges	-50 to +100 mA ¹	0.75 mA	100 mA
Temperature monitored by two, three or four-wire resistance thermometers	-200 to +850 °C		
low resistance range	0...740 Ω^1	8 Ω	740 Ω
high resistance range	0...5000 Ω^1	40 Ω	5000 Ω
Temperature monitored by thermocouples	-270 to +1820 °C	2 mV	300 mV
Variation of resistance of remote sensors/potentiometers			
low resistance range	0...740 Ω^1	8 Ω	740 Ω
high resistance range	0...5000 Ω^1	40 Ω	5000 Ω

¹ Note permissible value of the ratio "full-scale value/span ≤ 20 ".

² Max. **30 V** for **Ex** version with I.S. measuring input.

DC voltage

Measuring range limits:	See Table 1
Direct input:	Wiring diagram No. 1 ¹
Input resistance:	R _i > 10 MΩ Continuous overload max. -1.5 V, + 5 V
Input via potential divider:	Wiring diagram No. 2 ¹
Input resistance:	R _i = 1 MΩ Continuous overload max. ± 100 V

DC current

Measuring range limits:	See Table 1
Low currents:	Wiring diagram No. 3 ¹
Input resistance:	R _i = 24.7 Ω Continuous overload max. 150 mA
High currents:	Wiring diagram No. 3 ¹
Input resistance:	R _i = 24.7 Ω Continuous overload max. 150 mA

Resistance thermometer

Measuring range limits:	See Table 1 and 7
Resistance types:	Type Pt 100 (DIN IEC 751) Type Ni 100 (DIN 43 760) Type Pt 20/20 °C Type Cu 10/25 °C Type Cu 20/25 °C See "Table 5: Specification and ordering information", Feature 6 for other Pt or Ni.
Measuring current:	≤ 0.38 mA for measuring ranges 0...740 Ω or ≤ 0.06 mA for measuring ranges 0...5000 Ω
Standard circuit:	1 resistance thermometer: – two-wire connection, wiring diagram No. 4 ¹ – three-wire connection, wiring diagram No. 5 ¹ – four-wire connection, wiring diagram No. 6 ¹
Summation circuit:	Series or parallel connection of 2 or more two, three or four-wire resistance thermometers for deriving the mean temperature or for matching other types of sensors, wiring diagram No. 4 - 6 ¹

Differential circuit: 2 identical three-wire resistance thermometers for deriving the mean temperature RT1–RT2 wiring diagram No. 7¹

Input resistance: R_i > 10 MΩ
Lead resistance: ≤ 30 Ω per lead

Thermocouples

Measuring range limits:	See Table 1 and 7
Thermocouple pairs:	Type B: Pt30Rh-Pt6Rh (IEC 584) Type E: NiCr-CuNi (IEC 584) Type J: Fe-CuNi (IEC 584) Type K: NiCr-Ni (IEC 584) Type L: Fe-CuNi (DIN 43710) Type N: NiCrSi-NiSi (IEC 584) Type R: Pt13Rh-Pt (IEC 584) Type S: Pt10Rh-Pt (IEC 584) Type T: Cu-CuNi (IEC 584) Type U: Cu-CuNi (DIN 43710) Type W5-W26 Re Other thermocouple pairs on request

Standard circuit: 1 thermocouple, internal cold junction compensation, wiring diagram No. 8¹
1 thermocouple, external cold junction compensation, wiring diagram No. 9¹

Summation circuit: 2 or more thermocouples in a summation circuit for deriving the mean temperature, external cold junction compensation, wiring diagram No. 10¹

Differential circuit: 2 identical thermocouples in a differential circuit for deriving the mean temperature TC1 – TC2, no provision for cold junction compensation, wiring diagram No. 11¹

Input resistance: R_i > 10 MΩ

Cold junction compensation:

Internal or external
Internal: Compensating resistor Ni 100 plugged onto backplane BP 902

Permissible variation of the internal cold junction compensation: ± 0.5 K at 23 °C, ± 0.25 K/10 K

External: 0...70 °C, programmable

¹ See "Table 8: Measuring input".

Plug-in module SIRAX V 644

Programmable universal transmitter

Resistance sensor, potentiometer

Measuring range limits:	See Table 1
Resistance sensor types:	Type WF Type WF DIN Potentiometer see "Table 5: Specification and ordering information", Feature 5.
Measuring current:	≤ 0.38 mA at measuring range 0...740 Ω or ≤ 0.06 mA at measuring range 0...5000 Ω
Kinds of input:	1 resistance sensor WF current measured at pick-up, wiring diagram No. 12 ¹ 1 resistance sensor WF DIN current measured at pick-up, wiring diagram No. 13 ¹ 1 resistance sensor for two, three or four-wire connection, wiring diagram No. 4-6 ¹ 2 identical three-wire resistance sensors for deriving a differential, wiring diagram No. 7 ¹
Input resistance:	$R_i > 10$ M Ω
Lead resistance:	≤ 30 Ω per lead

Measuring output

Output signals A1 and A2

The output signals available at A1 and A2 can be configured for either an impressed DC current I_A or a superimposed DC voltage U_A by appropriately setting DIP switches. The desired range is programmed using a PC. A1 and A2 are not DC isolated and exhibit the same value.

Standard ranges for I_A:	0...20 mA or 4...20 mA
Non-standard ranges:	Limits -22 to + 22 mA Min. span 5 mA Max. span 40 mA
Open-circuit voltage:	Neg. -13.2...-18 V, pos. 16.5...21 V
Burden voltage I_{A1} :	+ 15 V, resp. -12 V
External resistance I_{A1} :	$R_{\text{ext}} \text{ max. [k}\Omega\text{]} = \frac{15 \text{ V}}{I_{\text{AN}} \text{ [mA]}}$ $\text{resp.} = \frac{-12 \text{ V}}{I_{\text{AN}} \text{ [mA]}}$ $I_{\text{AN}} = \text{full-scale output current}$
Burden voltage I_{A2} :	< 0.3 V

External resistance I_{A2} :	$R_{\text{ext}} \text{ max. [k}\Omega\text{]} = \frac{0.3 \text{ V}}{I_{\text{AN}} \text{ [mA]}}$
Residual ripple:	< 1% p.p., DC ... 10 kHz < 1.5% p.p. for an output span < 10 mA
Standard ranges for U_A:	0...5, 1...5, 0...10 or 2...10 V
Non-standard ranges:	Limits -12 to + 15 V Min. span 4 V Max. span 27 V
Short-circuit current:	≤ 40 mA
Load capacity U_{A1} / U_{A2} :	20 mA
External resistance U_{A1} / U_{A2} :	$R_{\text{ext}} \text{ [k}\Omega\text{]} \geq \frac{U_A \text{ [V]}}{20 \text{ mA}}$
Residual ripple:	< 1% p.p., DC ... 10 kHz < 1.5% p.p. for an output span < 8 V

Fixed settings for the output signals A1 and A2

After switching on:	A1 and A2 are at a fixed value for 5 s after switching on (default). Setting range -10 to + 110% ² programmable, e.g. between 2.4 and 21.6 mA (for a scale of 4 to 20 mA). The green LED flashes for the 5 s
---------------------	---

When input variable out of limits:	A1 and A2 are at either a lower or an upper fixed value when the input variable falls more than 10% below the minimum value of the permissible range ... exceeds the maximum value of the permissible range by more than 10%.
------------------------------------	---

Lower fixed value = -10% ² , e.g. -2 mA (for a scale of 0 to 20 mA). Upper fixed value = + 110% ² , e.g. 22 mA (for a scale of 0 to 20 mA). The green LED flashes

Open-circuit sensor:	A1 and A2 are at a fixed value when an open-circuit sensor is detected (see Section "Sensor and open-circuit lead supervision"). The fixed value of A1 and A2 is configured to either maintain their values at the instant the open-circuit occurs or adopt a preset value between -10 and + 110% ² , e.g. between 1.2 and 10.8 V (for a scale of 2 to 10 V). The green LED flashes and the red LED lights continuously
----------------------	--

¹ See "Table 8: Measuring input".

² In relation to analogue output span A1 resp. A2.

Output characteristic

Characteristic: Programmable

Table 2: Available characteristics (acc. to measured variable)

Measured variables	Characteristic		
DC voltage			
DC current			
Resistance thermometer (linear variation of resistance)			
Thermocouple signal (linear variation of voltage)			
Sensor or potentiometer	$A = M$		
DC voltage			
DC current		$A = \sqrt{M}$ or $A = \sqrt[3]{M^3}$	
DC voltage		Special characteristics	
DC current			$A = f(M)$ linearised ¹
Resistance thermometer (linear variation with temperature)			
Thermocouple signal (linear variation with temperature)			
Sensor or potentiometer			
DC voltage		Special characteristics	
DC current			$A = f(M)$ quadratic ²
Sensor or potentiometer			

Operating sense: Programmable output signal directly or inversely proportional to measured variable

Setting time (IEC 770): Programmable from 2 to 30 s

¹ 25 input points M given referred to a linear output scale from -10% to $+110\%$ in steps of 5% .

Power supply H →○

DC, AC power pack (DC and 45...400 Hz)

Table 3: Rated voltages and permissible variations

Nominal voltages U_N	Permissible variation	Instrument version
24... 60 V DC / AC	DC $-15...+33\%$ AC $\pm 15\%$	Standard (non-Ex)
85...230 V ³ DC / AC		
24... 60 V DC / AC	DC $-15...+33\%$ AC $\pm 15\%$	Type of protection "Intrinsically safe" [EEEx ia] IIC
85...230 V AC		
85...110 V DC	$-15...+10\%$	

Power consumption: ≤ 1.4 W resp. ≤ 2.7 VA

Open-circuit sensor circuit supervision

Resistance thermometers, thermocouples, remote sensors and potentiometer input circuits are supervised. The circuits of DC voltage and current inputs are not supervised.

Pick-up/reset level: 1 to 15 k Ω acc. to kind of measurement and range

Signalling modes

Output signals A1 and A2: Programmable fixed values. The fixed value of A1 and A2 is configured to either maintain their values at the instant the open-circuit occurs or adopt a preset value between -10 and $+110\%$ ⁴, e.g. between 1.2 and 10.8 V (for a scale of 2 to 10 V)

Frontplate signals: The green LED flashes and the red LED lights continuously

Output contact K: **Relay** 1 potentially-free changeover contact (see Table 4)
Operating sense programmable
The relay can be either energized or de-energized in the case of a disturbance.
Set to "Relay inactive" if not required!

² 25 input points M given referred to a quadratic output scale from -10% to $+110\%$. Pre-defined output points: 0, 0, 0, 0.25, 1, 2.25, 4.00, 6.25, 9.00, 12.25, 16.00, 20.25, 25.00, 30.25, 36.00, 42.25, 49.00, 56.25, 64.00, 72.25, 81.00, 90.25, 100.0, 110.0, 110.0%.

³ An external supply fuse must be provided for DC supply voltages > 125 V.

⁴ In relation to analogue output span A1 resp. A2.

Plug-in module SIRAX V 644

Programmable universal transmitter

Supervising a limit GW (⌈)

This Section only applies to transmitters which are **not** configured to use the output contact K in conjunction with the open-circuit sensor supervision (see Section "Open-circuit sensor circuit supervision").

This applies ...

... in all cases when the measured variable is a DC voltage or current)

... when the measured variable is a resistance thermometer, a thermocouple, a remote sensor or a potentiometer and the relay is set to "Relay de-energized"

Limit: Programmable

- De-energized
- Lower limit value of the measured variable (see Fig. 5, left)
- Upper limit value of the measured variable (see Fig. 5, left)
- Maximum rate of change of the measured variable

$$\text{Gradient} = \frac{\Delta \text{ measured variable}}{\Delta t}$$

(see Fig. 5, right)

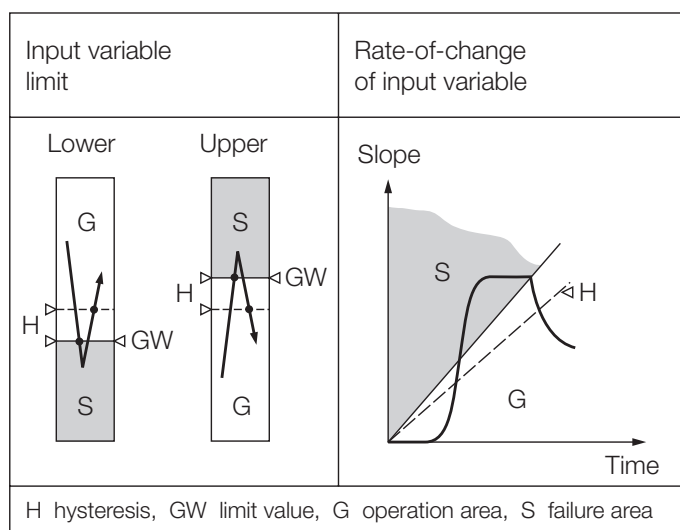

Fig. 5. Switching function according to limit monitored.

Trip point setting
using PC for GW:

Programmable

- between – 10 and + 110%¹ (of the measured variable)
- between ± 1 and ± 50%/s¹ (of the rate-of-change of the measured variable)

Reset ratio:

Programmable

- between 0,5 and 100%¹ (of the measured variable)
- between 1 and 100%/s¹ (of the rate-of-change of the measured variable)

Operating and resetting delays:

Programmable
– between 1 to 60 s

Operating sense:

Programmable

- Relay energized, red LED on
- Relay energized, red LED off
- Relay de-energized, red LED on
- Relay de-energized, red LED off (once limit reached)

Relay status signal:

GW by red LED (⌈)

Table 4: Contact arrangement and data

Symbol	Material	Contact rating
	Gold flashed silver alloy	AC: ≤ 2 A / 250 V (500 VA) DC: ≤ 1 A / 0.1...250 V (30 W)

Relay approved by UL, CSA, TÜV, SEV

Programming connector

Interface: RS 232 C
FCC-68 socket: 6/6 pin
Signal level: TTL (0/5 V)
Power consumption: Approx. 50 mW

Accuracy data (acc. to DIN/IEC 770)

Basic accuracy: Max. error ≤ ± 0.2%
Including linearity and repeatability errors for current, voltage and resistance measurement

Additional error (additive):

- < ± 0.3% for linearised characteristic
- < ± 0.3% for measuring ranges < 5 mV, 0.3...0.75 V, < 0.2 mA or < 20 Ω
- < ± 0.3% for a high ratio between full-scale value and measuring range > factor 10, e.g. Pt 100 175.84 Ω...194.07 Ω ≥ 200 °C...250 °C
- < ± 0.3% for current output < 10 mA span
- < ± 0.3% for voltage output < 8 V span
- < 2 · (basic and additional error) for two-wire resistance measurement

¹ In relation to analogue output span A1 resp. A2.

Reference conditions:

Ambient temperature	23 °C, ± 2 K
Power supply	24 V DC ± 10% and 230 V AC ± 10%
Output burden	Current: $0.5 \cdot R_{\text{ext}}$ max. Voltage: $2 \cdot R_{\text{ext}}$ min.

Influencing factors:

Temperature	< ± 0.1 ... 0.15% per 10 K
Burden	< ± 0.1% for current output < 0.2% for voltage output, providing $R_{\text{ext}} > 2 \cdot R_{\text{ext}}$ min.
Long-time drift	< ± 0.3% / 12 months
Switch-on drift	< ± 0.5%
Common and transverse mode influence	< ± 0.2%
+ or – output connected in ground:	< ± 0.2%

Installation data

Housing:	Transmitter in housing B17 for plugging onto backplane BP 902. Refer to Section “Dimensional drawing” for dimensions
Material of housing:	Lexan 940 (polycarbonate) Flammability Class V-0 acc. to UL 94, self-extinguishing, non-dripping, free of halogen
Designation:	SIRAX V 644
Mounting position:	Any
Electrical connections:	96-pin connector acc. to DIN 41 612, pattern C Layout see Section “Electrical connections”
Coding:	Transmitter supplied already coded. The rack is coded by the user by fitting the coding inserts supplied
Weight:	Approx. 0.18 kg

Electrical insulation:

All circuits (measuring input/measuring outputs/power supply/output contact) are electrically insulated.

Programming connector and measuring input are connected.

The PC is electrically insulated by the programming cable PRKAB 600.

Standards

Electromagnetic compatibility:	The standards DIN EN 50 081-2 and DIN EN 50 082-2 are observed
Intrinsically safe:	Acc. to DIN EN 50 020: 1996-04
Electrical design:	Acc. to IEC 1010 resp. EN 61 010
Protection (acc. to IEC 529 resp. EN 60 529):	Housing IP 40 Terminals IP 00
Operating voltage:	Measuring input < 40 V Programming connector, measuring outputs < 25 V Output contact, Power supply < 250 V
Rated insulation voltage:	Measuring input, programming connector, measuring outputs, output contact, power supply < 250 V
Pollution degree:	2
Installation category II:	Measuring input, programming connector, measuring outputs, output contact
Installation category III:	Power supply
Protection against electric shock:	Acc. to IEC 1010 resp. EN 61 010 and DIN/VDE 106, Part 101
Test voltage:	Measuring input and programming connector to: – Measuring outputs 2.3 kV, 50 Hz, 1 min. – Power supply 3.7 kV, 50 Hz, 1 min. – Output contact 2.3 kV, 50 Hz, 1 min. Measuring outputs to: – Power supply 3.7 kV, 50 Hz, 1 min. – Output contact 2,3 kV, 50 Hz, 1 Min. Serial interface for the PC to: – everything else 4 kV, 50 Hz, 1 min. (PRKAB 600)

Ambient conditions

Commissioning temperature:	– 10 to + 40 °C
Operating temperature:	– 25 to + 40 °C, Ex – 20 to + 40 °C
Storage temperature:	– 40 to + 70 °C
Relative humidity annual mean:	≤ 75%

Plug-in module SIRAX V 644

Programmable universal transmitter

Configuration

Special configuration

See "Table 5: Specification and ordering information"

Basic configuration

The transmitter SIRAX V 644 is available already programmed with a **basic** configuration which is especially recommended in cases where the programming data is not known at the time of ordering.

SIRAX V 644 supplied as standard versions are programmed for **basic** configuration (see Section "Standard versions").

Basic configuration:

- Measuring input 0...5 V DC
- Measuring output 0...20 mA linear, fixed value 0% during 5 s after switching on
- Setting time 0.7 s
- Open-circuit supervision inactive
- Mains ripple suppression 50 Hz
- Output contact inactive

Standard versions

The following transmitter versions are already programmed for **basic** configuration and are available ex stock. It is only necessary to quote the **Order No.:**

Instruments in standard (non Ex) version

Delivery	Plug-in cold junction compensating resistor Ni 100	Power supply	Order Code	Order No.
Transmitter for plugging onto backplane BP 902 (without BP 902)	without	24... 60 V DC / AC	644-6110	998 809
		85...230 V DC / AC	644-6210	107 913

Instruments in [EEx ia] IIC version

Delivery	Plug-in cold junction compensating resistor Ni 100	Power supply	Order Code	Order No.
Transmitter for plugging onto backplane BP 902 (without BP 902)	without	24... 60 V DC / AC	644-6310	107 921
		85...110 V DC/85...230 V AC	644-6410	107 939

The complete Order Code 644-... and/or a description according to Table 5: "Specification and ordering information" must be stated for versions other than the basic version and for special configurations. Where the backplane BP 902 is required, order it as a separate item. Order Informations see data sheets for SIRAX backplane.

Where one is required, order the reference point compensating resistor Ni 100 as a separate item, see Table 9: "Accessories and spare parts".

Table 5: Specification and ordering information

Order Code 644 -						
Features, Selection	*SCODE	no-go	6	.	.	.
1. Mechanical design						
6) Housing B17 (for plugging onto backplane BP 902, see data sheets BP 902)						
2. Version / Power supply H (nominal voltage U_N)						
1) Standard	/ 24... 60 V	DC/AC	.	1	.	.
2) Standard	/ 85...230 V	DC/AC	.	2	.	.
3) [EEx ia] IIC	/ 24... 60 V	DC/AC	.	3	.	.
4) [EEx ia] IIC	/ 85...110 V	DC	.	4	.	.
	85...230 V	AC				
Lines 3 and 4: Instrument [EEx ia] IIC, measuring circuit EEx ia IIC						
3. Climatic rating / Cold junction compensation						
1) Standard climatic rating; instrument without cold junction compensating resistor			.	1	.	.
Compensating resistor Ni 100 for plugging onto backplane BP 902 (see Table 9)						
4. Configuration						
1) Programmed to order			.	.	1	.
2) Programmed to order with test certificate			.	.	2	.
5. Measured variable / Measuring input M						
DC voltage						
0) 0... 5 V linear		C	.	.	0	.
1) 1... 5 V linear		C	.	.	1	.
2) 0...10 V linear		C	.	.	2	.
3) 2...10 V linear		C	.	.	3	.
4) Linear input, other ranges	[V]	C	.	.	4	.
5) Square root input function	[V]	C	.	.	5	.
6) Input X ^{3/2} -function	[V]	C	.	.	6	.
Lines 4 to 6: DC [V] 0...0.002 to 0...≤ 40 V (Ex max. 30 V) or span 0.002 to 40 V between - 40 and + 40 V, ratio full-scale/span ≤ 20						

Feature “5. Measured variable / Measuring input M” continued on next page!

Plug-in module SIRAX V 644

Programmable universal transmitter

Order Code 644 -			*SCODE	no-go
Features, Selection				
5. Measured variable / Measuring input M (continuation)				
DC current				
7) 0...20 mA linear			C	
8) 4...20 mA linear			C	
9) Linear input, other ranges [mA]			C	
A) Square root input function [mA]			C	
B) Input $X^{\frac{3}{2}}$ -function [mA]			C	
Lines 9, A and B: DC [mA] 0...0.08 to 0...100 mA or span 0.08 to 100 mA between - 50 and + 100 mA, ratio full-scale/span ≤ 20				
Resistance thermometer, linearised				
C) Two-wire connection, R_L [Ω]			E	
D) Three-wire connection, $R_L \leq 30 \Omega$ /wire			E	
E) Four-wire connection, $R_L \leq 30 \Omega$ /wire			E	
Resistance thermometer, non-linearised				
F) Two-wire connection, R_L [Ω]			E	
G) Three-wire connection, $R_L \leq 30 \Omega$ /wire			E	
H) Four-wire connection, $R_L \leq 30 \Omega$ /wire			E	
J) Temperature difference [deg]			E	
2 identical resistance thermometers in three-wire connection				
Lines C and F: Specify total lead resistance R_L [Ω], any value between 0 and 60 Ω . This may be omitted, because two leads can be compensated automatically on site				
Line J: Temperature difference; specify measuring range [deg], also for feature 6.: t_{min} ; t_{max} ; $t_{reference}$				
Thermocouple linearised				
K) Internal cold junction compensation (not for type B)			DT	
L) External cold junction compensation tK [$^{\circ}$ C]			D	
(specify 0 $^{\circ}$ C for type B)*				
Thermocouple non-linearised				
M) Internal cold junction compensation (not for type B)			DT	
N) External cold junction compensation tK [$^{\circ}$ C]			D	
(specify 0 $^{\circ}$ C for type B)*				
P) Average temperature [n]			D	
Q) Temperature difference [deg]			D	
2 identical thermocouples				
Lines L, N and P: Specify external cold junction temperature t_x [$^{\circ}$ C], any value between 0 and 70 $^{\circ}$ C				
Line P: State number of sensors [n]				
Line Q: Temperature difference; specify measuring range [deg], also for feature 6.: t_{min} ; t_{max} ; $t_{reference}$				

--	--	--	--	--	--	--	--	--	--

Insert code in
the 1st box
on the next
page!

7

8

9

A

B

C

D

E

F

G

H

J

K

L

M

N

P

Q

* Because of its characteristic, thermocouple type B does not require compensating leads nor cold junction compensation.

Feature "5. Measured variable / Measuring input M" continued on next page!

Order Code 644 -					
Features, Selection			*SCODE	no-go	
5. Measured variable / Measuring input M (continuation)					
Resistance transmitter / Potentiometer					
R) WF $R_L \leq 30 \Omega/\text{wire}$	Measuring range [Ω]		F		R
S) WF DIN $R_L \leq 30 \Omega/\text{wire}$	Measuring range [Ω]		F		S
T) Potentiometer Two-wire connection	Measuring range [Ω] and R_L [Ω]		F		T
U) Potentiometer Three-wire connection $R_L \leq 30 \Omega/\text{wire}$	Measuring range [Ω]		F		U
V) Potentiometer Four-wire connection $R_L \leq 30 \Omega/\text{wire}$	Measuring range [Ω]		F		V
<p>Lines R to V: Specify initial resistance, span and residual resistance in Ω; Example: 200...600...200; 0...500...0; 10...80...20 Minimum span at full-scale value ME: 8 Ω for ME \leq 740 Ω 40 Ω for ME > 740 Ω.</p> <p>Max. resistance value (initial value + span + lead resistance) 5000 Ω.</p> <p>Note: Initial measuring range < 10 x span</p> <p>Line T: Specify total lead resistance R_L [Ω], any value between 0 and 60 Ω. This may be omitted, because two leads can be compensated automatically on site</p>					
Special characteristic					
Z) For special characteristic	[V] [mA] [Ω]				Z
Fill in Table W 2357 e for special characteristic for V, mA or Ω input.					
6. Sensor type / Temperature range					
0) No temperature measurement					. 0
1) Pt 100	[$^{\circ}\text{C}$]			CDF	. 1
2) Ni 100	[$^{\circ}\text{C}$]			CDF	. 2
3) Other Pt [Ω]	[$^{\circ}\text{C}$]			CDF	. 3
4) Other Ni [Ω]	[$^{\circ}\text{C}$]			CDF	. 4
5) Pt 20 / 20 $^{\circ}\text{C}$	[$^{\circ}\text{C}$]			CDF	. 5
6) Cu 10 / 25 $^{\circ}\text{C}$	[$^{\circ}\text{C}$]			CDF	. 6
<p>Lines 1 to 6: Specify measuring range in [$^{\circ}\text{C}$] or $^{\circ}\text{F}$, refer to Table 7 for the operating limits for each type of sensors.</p> <p>For temperature difference measurement; specify measuring range and reference temperature for 2nd sensor (t_{\min}; t_{\max}; $t_{\text{reference}}$) e.g. 100; 250; 150</p> <p>Lines 3 and 4: Specify resistance in Ω at 0$^{\circ}\text{C}$; permissible values are 100 and 1000, multiplied or divided by a whole number e.g.: 1000 : 4 = 250, 100 : 2 = 50 or 100 x 3 = 300</p>					

Insert code in
the 1st box
of the next
page!

R
S
T
U
V

Z

. 0
. 1
. 2
. 3
. 4
. 5
. 6

Feature «6. Sensor type / Temperature range M» continued on next page!

Plug-in module SIRAX V 644

Programmable universal transmitter

Order Code 644 -								
Features, Selection				*SCODE	no-go			
6. Sensor type / Temperature range (continuation)								
B) Type B:	Pt30Rh-Pt6Rh	[°C]						B
E) Type E:	NiCr-CuNi	[°C]						E
J) Type J:	Fe-CuNi	[°C]						J
K) Type K:	NiCr-Ni	[°C]						K
L) Type L:	Fe-CuNi	[°C]						L
N) Type N:	NiCrSi-NiSi	[°C]						N
R) Type R:	Pt13Rh-Pt	[°C]						R
S) Type S:	Pt10Rh-Pt	[°C]						S
T) Type T:	Cu-CuNi	[°C]						T
U) Type U:	Cu-CuNi	[°C]						U
W) Type W5-W26Re		[°C]						W
Lines B to W: Specify measuring range in [°C] or °F, refer to Table 7 for the operating limits for each type of sensors. For temperature difference measurement; specify measuring range and reference temperature for 2nd sensor (t_{min} ; t_{max} ; $t_{reference}$), e.g. 100; 250; 150								
7. Output signal / Measuring output A1*								
0)	0...20 mA, $R_{ext} \leq 750 \Omega$. 0
1)	4...20 mA, $R_{ext} \leq 750 \Omega$. 1
2)	Non-standard	[mA]						. 2
3)	0... 5 V, $R_{ext} \geq 250 \Omega$. 3
4)	1... 5 V, $R_{ext} \geq 250 \Omega$. 4
5)	0...10 V, $R_{ext} \geq 500 \Omega$. 5
6)	2...10 V, $R_{ext} \geq 500 \Omega$. 6
7)	Non-standard	[V]						. 7
Line 2: -22 to + 22, span 5 to 40 mA								
Line 7: -12 to + 15, span 4 to 27 V								
8. Output characteristic								
0)	Directly proportional, initial start-up value 0%							. . 0
1)	Inversely proportional, initial start-up value 100%							. . 1
2)	Directly proportional, initial start-up value	[%]						. . 2
3)	Inversely proportional, initial start-up value	[%]						. . 3
9. Output time response								
0)	Rated setting time approx. 1 s							. . . 0
1)	Others	[s]						. . . 1
Line 1: Any whole number from 2 to 30 s								

* 2nd output signal A2 for field indicator only.

Order Code 644 -					
Features, Selection			*SCODE	no-go	
10. Open-circuit sensor signalling Without / open-circuit sensor signal / relay / output signal A corresponding to input variable [%]					
0) No sensor signal (for current or voltage measurement)				DEF	0
1) With sensor signal / relay de-energized / output signal A % <input type="text"/>				C	1
2) With sensor signal / relay energized / output signal A % <input type="text"/>			K	C	2
3) With sensor signal / relay de-energized / output signal A % <input type="text"/>			K	C	3
4) With sensor signal / relay energized / hold A at last value			K	C	4
5) With sensor signal / relay de-energized / hold A at last value			K	C	5
Lines 1, 2 and 3: Specify value of output signal span in %, any value from -10% to + 110%; e.g. with output 4...20 mA corresponding 2.4 mA -10% and 21.6 mA + 110%					
Lines 2 to 5: Cannot be combined with active trip point GW, Feature 12. lines 1 to 3 and Feature 13. lines 1 and 2					
11. Mains ripple suppression					
0) Frequency 50 Hz					. 0
1) Frequency 60 Hz					. 1
12. Type and values of trip point GW and reset ratio, energizing delay and de-energizing delay (for output contact K)					
0) Alarm function inactive			L		. . 0
1) Low alarm [%;%s;s] <input type="text"/>			M	K	. . 1
2) High alarm [%;%s;s] <input type="text"/>			M	K	. . 2
3) Rate-of-change alarm dx/dt [%/s;%s;s] <input type="text"/>			M	K	. . 3
13. Sense of action of trip point (for GW resp. K)					
0) Alarm function inactive				M	. . . 0
1) Relay energized in alarm condition				KL	. . . 1
2) Relay energized in safe condition				KL	. . . 2

* Lines with letter(s) under "no-go" cannot be combined with preceding lines having the same letter under "SCODE".

Table 6: Data on explosion protection $\text{\textcircled{E}x}$ II (1) G

Order Code	Type of protection "Intrinsically safe"		Type test certificate	Mounting location of device
	Instrument	Marking Measuring input		
644 - 63.. 644 - 64..	[EEx ia] IIC	EEx ia IIC	PTB 97 ATEX 2074 X	Not in hazardous area

Important condition: The SIRAX V 644 may only be programmed using a PRKAB 600 with the component certificate PTB 97 ATEX 2082 U.

Plug-in module SIRAX V 644

Programmable universal transmitter

Table 6: Temperature measuring ranges

Measuring ranges [°C]	Resistance thermometer		Thermocouples									
	Pt100	Ni100	B	E	J	K	L	N	R	S	T	U
0... 20												
0... 25	X	X										
0... 40	X	X		X	X		X					
0... 50	X	X		X	X	X	X				X	X
0... 60	X	X		X	X	X	X				X	X
0... 80	X	X		X	X	X	X				X	X
0... 100	X	X		X	X	X	X	X			X	X
0... 120	X	X		X	X	X	X	X			X	X
0... 150	X	X		X	X	X	X	X			X	X
0... 200	X	X		X	X	X	X	X			X	X
0... 250	X	X		X	X	X	X	X			X	X
0... 300	X			X	X	X	X	X	X	X	X	X
0... 400	X			X	X	X	X	X	X	X	X	X
0... 500	X			X	X	X	X	X	X	X		X
0... 600	X			X	X	X	X	X	X	X		X
0... 800			X									
0... 900			X	X	X	X	X	X	X	X		
0...1000			X	X	X	X		X	X	X		
0...1200			X		X	X		X	X	X		
0...1500			X						X	X		
0...1600			X						X	X		
50... 150	X	X		X	X	X	X	X			X	X
100... 300	X			X	X	X	X	X			X	X
300... 600	X			X	X	X	X	X	X	X		X
600... 900			X	X	X	X	X	X	X	X		
600...1000			X	X	X	X		X	X	X		
900...1200			X		X	X		X	X	X		
600...1600			X						X	X		
600...1800			X									
-20... + 20	X	X		X	X		X					
-10... + 40	X	X		X	X	X	X					X
-30... + 60	X	X		X	X	X	X	X			X	X
Measuring range limits [°C]	-200 to + 850	-60 to + 250	0 to + 1820	-270 to + 1000	-210 to + 1200	-270 to + 1372	-200 to + 900	-270 to + 1300	-50 to + 1769	-50 to + 1769	-270 to + 400	-200 to + 600
	ΔR min 8 Ω at full-scale end value $\leq 740 \Omega$ ΔR min 40 Ω at full-scale end value $> 740 \Omega$ to 5000 Ω		ΔU min 2 mV									

Electrical connections

SIRAX V 644
Front

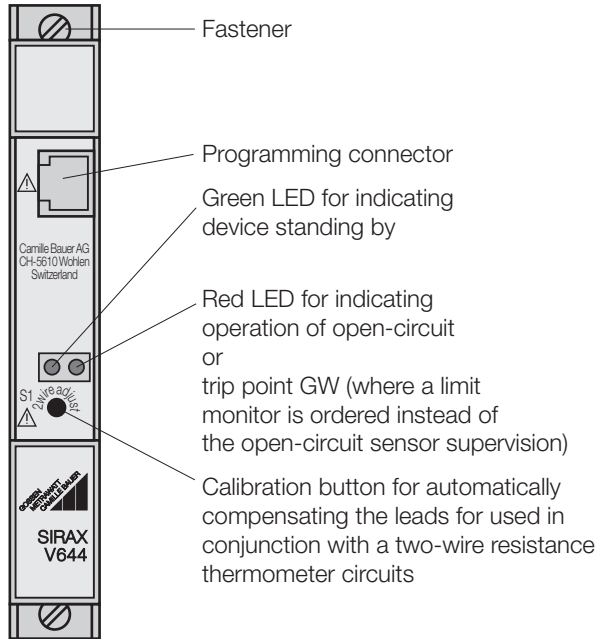

SIRAX V 644
Rear

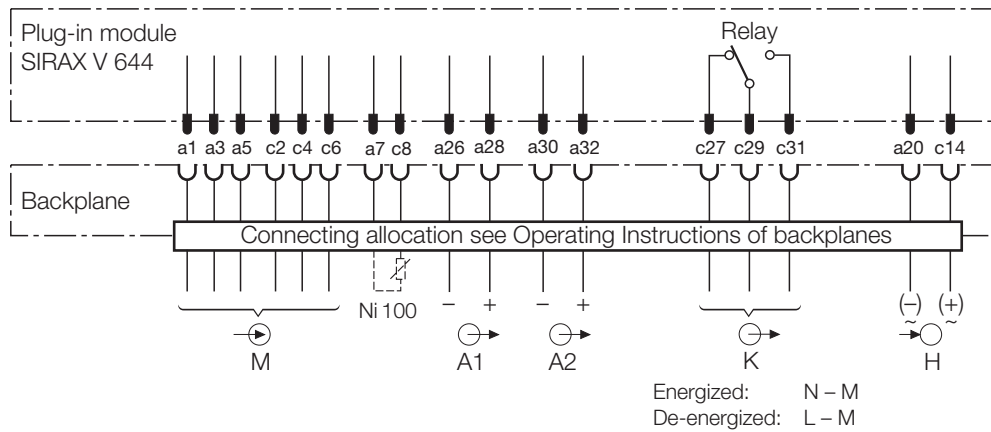
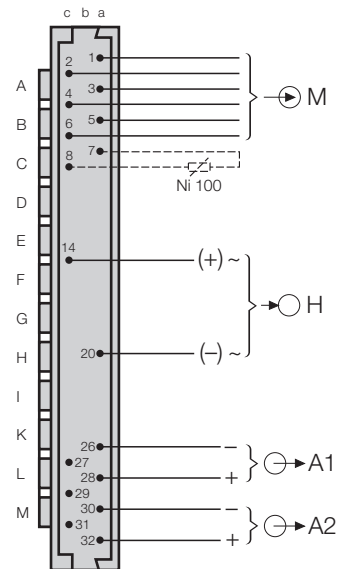

- M = Measured variable / measuring input,
Contact allocation acc. to the measuring mode and application, see "Table 8: Measuring input"
- A1 = Output signal / measuring output
- A2 = 2nd output (field indicator)
- K = Output contact for open-circuit sensor supervision or for monitoring a limit GW
- H = Power supply
- Ni 100 = Compensating resistor Ni 100 for plugging onto backplane BP 902

Plug-in module SIRAX V 644

Programmable universal transmitter

Table 8: Measuring input

Measurement	Measuring range limits	Measuring span	No.	Connecting diagram Plug wiring
DC voltage (direct input)	- 300...0...+300 mV	2...300 mV	1	
DC voltage (input via potential divider)	- 40...0...+40 V (Ex max. 30 V)	0.3...40 V	2	
DC current	- 12...0... +12 mA/ - 50...0...+100 mA	0.08... 12 mA/ 0.75...100 mA	3	
Resistance thermometer RTD or resistance measurement R, two-wire connection	0... 740 Ω / 0...5000 Ω	8... 740 Ω / 40...5000 Ω	4	
Resistance thermometer RTD or resistance measurement R, three-wire connection	0... 740 Ω / 0...5000 Ω	8... 740 Ω / 40...5000 Ω	5	
Resistance thermometer RTD or resistance measurement R, four-wire connection	0... 740 Ω / 0...5000 Ω	8... 740 Ω / 40...5000 Ω	6	
2 identical three-wire resistance thermometers RTD for deriving the difference	RTD1 - RTD2 0... 740 Ω / 0...5000 Ω	8... 740 Ω / 40...5000 Ω	7	
Thermocouple TC Cold junction compensation (Ni 100 plugged onto backplane BP 902)	- 300...0...+300 mV	2...300 mV	8	
Thermocouple TC Cold junction compensation external	- 300...0...+300 mV	2...300 mV	9	
Thermocouple TC in a summation circuit for deriving the mean temperature	- 300...0...+300 mV	2...300 mV	10	
Thermocouple TC in a differential circuit for deriving the mean temperature	TC1 - TC2 - 300...0...+300 mV	2...300 mV	11	
Resistance sensor WF	0... 740 Ω / 0...5000 Ω	8... 740 Ω / 40...5000 Ω	12	
Resistance sensor WF DIN	0... 740 Ω / 0...5000 Ω	8... 740 Ω / 40...5000 Ω	13	

Table 9: Accessories and spare parts

Description	Order No.
Coding comb with 12 sets of codes (for coding the backplane BP 902)	107 971
Programming cable PRKAB 600 for SINEAX/EURAX VC 603/V 604, SIRAX V 644 and SINEAX TV 809	147 787
Ancillary cable for SINEAX/EURAX VC 603/V 604 and SIRAX V 644	988 058
Configuration Software VC 600 for SINEAX/EURAX VC 603 / V 604 and SIRAX V 644 Windows 3.1x, 95, 98, NT and 2000 incl. V 600 (Version 1.6, DOS) on CD in German, English, French and Dutch (Download free of charge under http://www.gmc-instruments.com) In addition, the CD contains all configuration programmes presently available for Camille Bauer products.	146 557

Description	Order No.
Cold junction compensating resistor Ni 100 (for plugging onto backplane BP 902)	107 905
Data card (for recording programmed settings)	124 727
Operating Instructions V 644-6 B d-f-e	107 947

Dimensional drawing

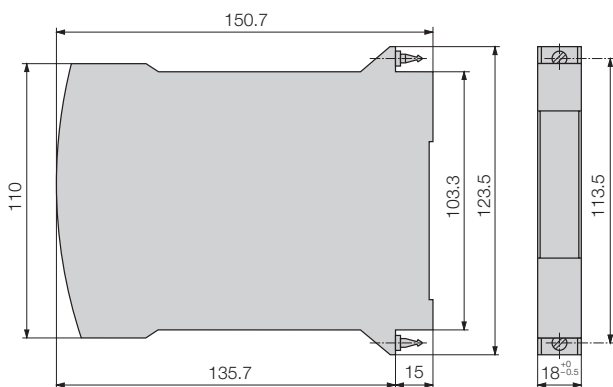

Fig. 6. SIRAX V 644 in housing B17.

Standard accessories

- 1 Operating Instructions for SIRAX V 644, in three languages:
German, French, English
- 1 Coding comb with 12 sets of codes
- 3 Data cards (for recording programmed settings)
- 1 Type test certificate (only for instruments in type of protection
"Intrinsically safe")

Plug-in module SIRAX V 644

Programmable universal transmitter

Printed in Germany • Subject to change without notice • Edition 03.01 • Data sheet No. V 644-6 Le

Aargauerstrasse 7
CH-5610 Wohlen/Switzerland
Phone +41 56 618 21 11
Fax +41 56 618 24 58
e-mail: cbag@gmc-instruments.com
<http://www.gmc-instruments.com>

Camille Bauer Ltd

GOSSEN
METRAWATT
CAMILLE BAUER 