

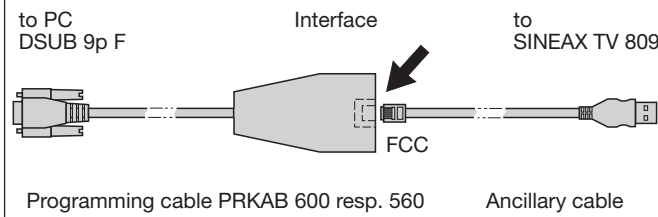

1. The programming connector must not be connected when > 253 V could be applied to the SINEAX TV 809 input circuit.
2. The SINEAX TV 809 programming connector must only be used with the PRKAB 600 resp. 560 and its ancillary cable.
3. The ancillary cable must first be connected to the PRKAB 600 resp. 560 before it is connected to the TV 809 (see arrow).
4. The programming connector is galvanically connected to the input circuit. Therefore no metal parts of the plug or socket may be touched.
5. The PRKAB 600 resp. 560 must not be used with other devices.
6. After programming is complete, the programming connection must be removed from the TV 809.



## 9. Accessories and spare parts

Description	Order No.
Programming cable PRKAB 560 (for programming the SINEAX TV 809 non-Ex)	147 779
Programming cable PRKAB 600 (for programming the SINEAX TV 809 Ex)	147 787
Ancillary cable SINEAX type TV 809	143 587
<b>Configuration software TV 800 plus</b> for SINEAX TV 809 Windows 95 or higher on CD, in different languages <b>(Download free of charge under <a href="http://www.camillebauer.com">http://www.camillebauer.com</a>)</b> In addition, the CD contains all configuration programmes presently available for Camille Bauer products	146 557
Operating Instructions TV 809 Bd in German	147 422
Operating Instructions TV 809 Bf in French	147 795
Operating Instructions TV 809 Be in English	147 802

## 10. Commissioning

Switch on the measuring input and the power supply.



The power supply unit must be capable of supplying a brief current surge when switching on. The isolating amplifier presents a low impedance at the instant of switching which requires a current  $I_{start}$  of ...

...  $I_{start} \geq 160 \text{ mA}$  for the version with a power supply range of 24 – 60 V DC, AC

or

...  $I_{start} \geq 35 \text{ mA}$  for the version with a power supply range of 85 – 230 V DC, AC

## 11. Maintenance

No maintenance is required.

## 12. Releasing the isolating amplifier

Release the instrument from a top-hat rail as shown in Fig. 7.

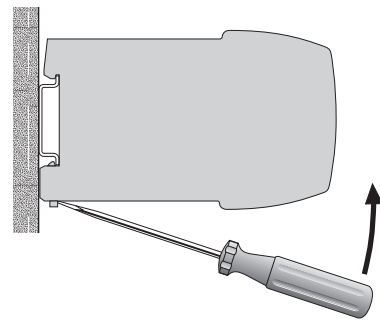

Fig. 7

## 13. Dimensional drawings

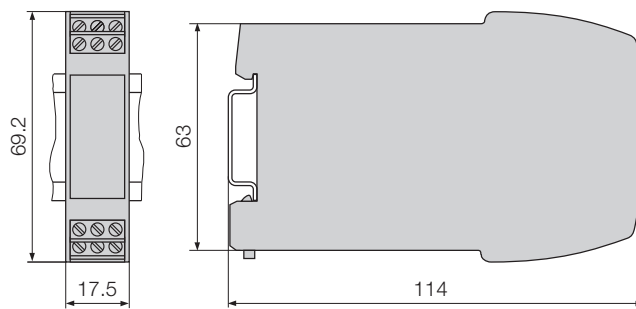

Fig. 8. SINEAX TV 809 in carrying rail housing **P12/17** clipped onto a top-hat rail (35 x 15 mm or 35 x 7.5 mm, acc. to EN 50 022), **screw terminals not pluggable**.

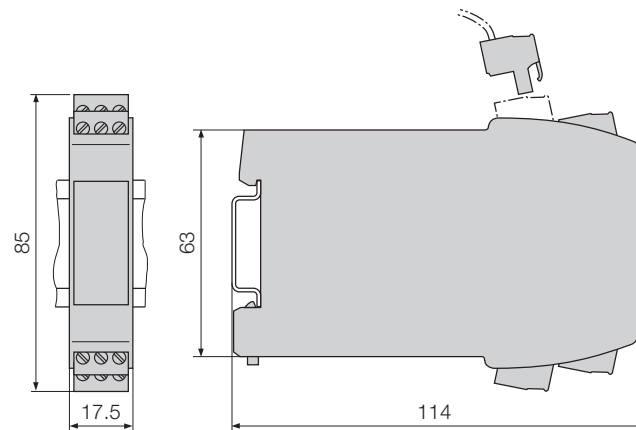

Fig. 9. SINEAX TV 809 in carrying rail housing **P12/17 St** clipped onto a top-hat rail (35 x 15 mm or 35 x 7.5 mm, acc. to EN 50 022), **screw terminals pluggable**.

The following symbols in the Operating Instructions indicate safety precautions which must be strictly observed:



## Contents

1. Read first and then ...	1
2. Scope of supply	1
3. Brief description	1
4. Overview of the parts	2
5. Technical data	2
6. Mounting	2
7. Electrical connections	2
8. Configuring the isolating amplifier	3
9. Accessories and spare parts	4
10. Commissioning	4
11. Maintenance	4
12. Releasing the isolating amplifier	4
13. Dimensional drawings	4

## 1. Read first and then ...



The proper and safe operation of the device assumes that the Operating Instructions are **read** and the safety warnings given in the various Sections

- 6. Mounting**
- 7. Electrical connections**
- 8. Configuring the isolating amplifier**
- 10. Commissioning**

are **observed**.

The device should only be handled by appropriately trained personnel who are familiar with it and authorised to work in electrical installations.

Unauthorized repair or alteration of the unit invalidates the warranty.

## 2. Scope of supply (Fig. 1 and 2)

**Isolating amplifier**, one of the two versions (1)  
Order Code: Significance of the 1st to 7th digits

809 - x x x	
3	Housing with screw terminals, not pluggable
9	Housing with screw terminals, pluggable
1	Standard / Power supply 24 ... 60 V DC, AC
2	Standard / Power supply 85 ... 230 V DC, AC
3	[EEx ia] IIC / Power supply 24 ... 60 V DC, AC
4	[EEx ia] IIC / Power supply 85 ... 110 V DC / 230 V AC
1	Input current max. final value 100 mA (Standard)
2	Input current max. final value 1.5 mA



Camille Bauer Ltd  
Aargauerstrasse 7  
CH-5610 Wohlen/Switzerland  
Phone +41 56 618 21 11  
Fax +41 56 618 24 58  
e-mail: [info@camillebauer.com](mailto:info@camillebauer.com)  
<http://www.camillebauer.com>

TV 809 Be 147 802 08.04

809 - x x x x	
0	Without alarm function
1	With built-in alarm relay
0	Without test records
D	With test records in German
E	With test records in English

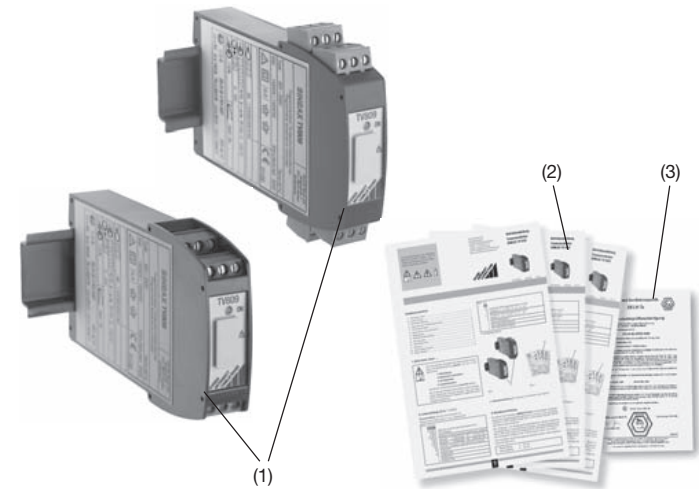

Fig. 1

Fig. 2

1 **Operating Instructions** (2) each in German, French and English  
1 **Ex approval** (3), only for Ex version devices

## 3. Brief description

The purpose of the isolating amplifier **SINEAX TV 809** is to electrically insulate input and output signals, respectively to amplify and/or change the signal level or type (current or voltage) of the input signals.

An explosion-proof "intrinsically safe" [EEx ia] IIC version rounds off this series of SINEAX TV 809.

Measured variables and measuring ranges are programmed with the aid of a PC, a programming cable and the programming software. Specific measured variable data such as output signal, transmission characteristics and various functions in combination with the alarm function can also be programmed.

Isolating amplifier supplied as standard versions are configured as follows:

- Measuring input:	4 ... 20 mA
- Measuring output:	4 ... 20 mA
- Response time:	80 ms
- Mains ripple suppression:	For frequency 50 Hz

## 4. Overview of the parts

Figure 3 shows those parts of the device of consequence for electrical connections and other operations described in the Operating Instructions.

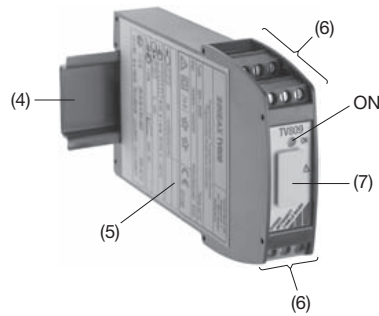

Fig. 3

- (4) Top-hat rail 35 x 15 mm or 35 x 7.5 mm (EN 50 022)
- (5) Type label
- (6) Terminals
- ON Green LED to indicate the operating state and limit exceeded. The LED flashes (option)
- (7) Programming connector

## 5. Technical data

### Measuring input

Input variable and measuring range configured

**DC current:** Type 809 – xx1  
Start value/final value between – 100 and 100 mA,  $R_i = 15.4 \Omega$   
Any point may be zero  
Type 809 – xx2  
Start value/final value between – 1.5 and 1.5 mA,  $R_i = 1 \text{ k}\Omega$   
Any point may be zero

**DC voltage:** **EEx version max. 30 V**  
 $\leq \pm 1.7 \text{ V}$ ,  $R_i = 1 \text{ M}\Omega$   
 $> \pm 1.7 \text{ to } \pm 100 \text{ V}$ ,  $R_i = 540 \text{ k}\Omega$   
 $> \pm 100 \text{ to } \pm 1000 \text{ V}$ ,  $R_i = 5.5 \text{ M}\Omega$   
Reduced safety

### Measuring output

**DC current\*:** Programmable, reference range – 20 ... 20 mA, start and final values anywhere within the reference range, also with reversed direction e.g. 20 ... 4 mA

External resistance:  $R_{\text{ext}} \text{ max. } \leq 600 \Omega$  with 20 mA output

**DC voltage\*:** Programmable, reference range – 10 ... 10 V, start and final values anywhere within the reference range, also with reversed direction e.g. + 10 ... – 5 V

Load capacity:  $R_{\text{ext}} \text{ min. } \geq 1000 \Omega$  with 10 V output

### Programming connector on isolating amplifier

Interface: Serial interface

### Power supply

DC, AC power pack (DC or 45...400 Hz)

Rated voltages and permissible variations

Nominal voltage $U_N$	Tolerance	Instruments version
24... 60 V DC, AC	DC – 15...+ 33%	Standard (Non-Ex)
85...230 V** DC, AC	AC $\pm 15\%$	
24... 60 V DC, AC	DC – 15...+ 33%	Type of protection "Intrinsic safety" [EEx ia] IIC
85...230 V AC	$\pm 10\%$	
85...110 V DC	– 15...+ 10%	

Power consumption:  $\leq 1.2 \text{ W}$  resp.  $\leq 2.5 \text{ VA}$

## Light emitting diodes

Green LED: Light after switching on the power supply

### Output contact

Relay: For monitoring the measured value limit. 1 galvanically isolated switching contact

Contact rating: AC:  $\leq 2 \text{ A} / 250 \text{ V}$  (500 VA)  
DC:  $\leq 2 \text{ A} / 125 \text{ V}$  (60 W)

Material: Gold flashed silver alloy

Trip point type: Programmable as low or high trip point

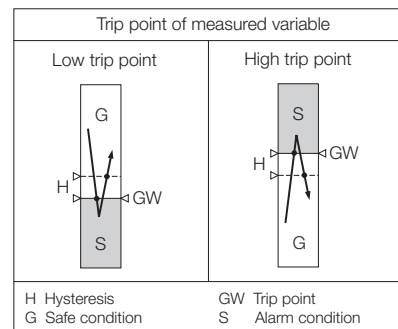

Fig. 4. Switching function, according to trip point type.

### Trip point adjustment

**with PC for trip point:** Programmable between – 10 and 110%\*\*\*

Hysteresis: Programmable between  $> 0$  and 100%\*\*\*

Energizing and de-energizing delays: Programmable between 0 to 1080 s

Relay contact position: Programmable

Frontplate signals: The green LED "ON" flashes when the limit value is exceeded

\* The type of output variable (current or voltage) is configurable with software  
\*\* An external supply fuse must be provided for DC supply voltages  $> 125 \text{ V}$   
\*\*\* In relation to the analog output value range

## 6. Mounting

The SINEAX TV 809 can be mounted on a top-hat rail.

**i** When deciding where to install the isolating amplifier (measuring location), take care that the **limits** of the operating temperature **are kept**:  
– 25 and + 55 °C

Simply clip the device onto the top-hat rail (EN 50 022) (see Fig. 5).

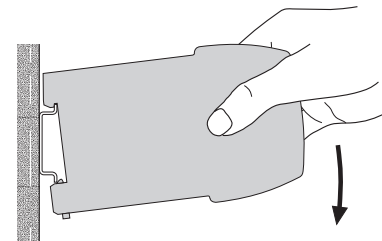

Fig. 5. Mounting onto top-hat rail 35 x 15 or 35 x 7.5 mm.

## 7. Electrical connections

The connections for the leads are fixed or plug-in screw terminals, depending on the device execution. These are easily accessible at the front of the isolating amplifier and are suitable for a wire cross-section of max. 2.5 mm<sup>2</sup>.

**⚡** Make sure that the cables are not live when making the connections!  
**Impending danger by high input voltage or high power supply voltage, 250 V at contact output.**



Also note that, ...

... the data required to carry out the prescribed measurement must correspond to those marked on the nameplate of SINEAX TV 809 (– measuring input, → measuring output and → power supply)!

... the resistance in the output circuit may not **overrange** the current output value

$$R_{\text{ext}} \text{ max. } [\text{k}\Omega] = \frac{12 \text{ V}}{I_{\text{AN}} [\text{mA}]}$$

( $I_{\text{AN}}$  = current output value)

and not **underrange** the voltage output value

$$R_{\text{ext}} \text{ min. } [\text{k}\Omega] \geq \frac{U_{\text{AN}} [\text{V}]}{10 \text{ mA}}$$

( $U_{\text{AN}}$  = voltage output value)

... the measurement input and output cables should be twisted pairs and run as far as possible away from heavy current cables!

In all other respects, observe all local regulations when selecting the type of electrical cable and installing them!



In the case of "Intrinsically safe" explosion-proof, the supplementary information given on the type examination certifications, the EN 60 079-14, and also local regulations applicable to electrical installation in explosion hazard areas must be taken into account.

Measuring mode/application	DC voltage			DC current	
	$\leq \pm 1.7 \text{ V}$	$> \pm 1.7 \text{ to } \pm 100 \text{ V}$	$> \pm 100 \text{ to } \pm 1000 \text{ V}$	$\leq \pm 100 \text{ mA}$	$\leq \pm 1.5 \text{ mA}$
Measuring range limits	$\leq \pm 1.7 \text{ V}$	$> \pm 1.7 \text{ to } \pm 100 \text{ V}$	$> \pm 100 \text{ to } \pm 1000 \text{ V}$	$\leq \pm 100 \text{ mA}$	$\leq \pm 1.5 \text{ mA}$
Measuring input					
Measuring output					
Output contact (Option)					
Power supply					

## 8. Configuring the isolating amplifier

A PC, the programming cable PRKAB 600 (for Ex instruments) resp. PRKAB 560 (for non-Ex instruments) plus ancillary cable and the configuration software TV 800 plus are required to program the isolating amplifier.

The connections between "PC ↔ PRKAB 600 resp. 560 ↔ SINEAX TV 809" can be seen from Fig. 6. The power supply must be connected in order to configure the SINEAX TV 809.

The software TV 800 plus is supplied on a CD and runs under Windows 95 or higher.

The menu driven configuration software explains how to configure the TV 809 and the choice of parameters.

The programming cable PRKAB 600 resp. PRKAB 560 adapts the signal level and provides galvanic isolation between the PC and the SINEAX TV 809 isolating amplifier.

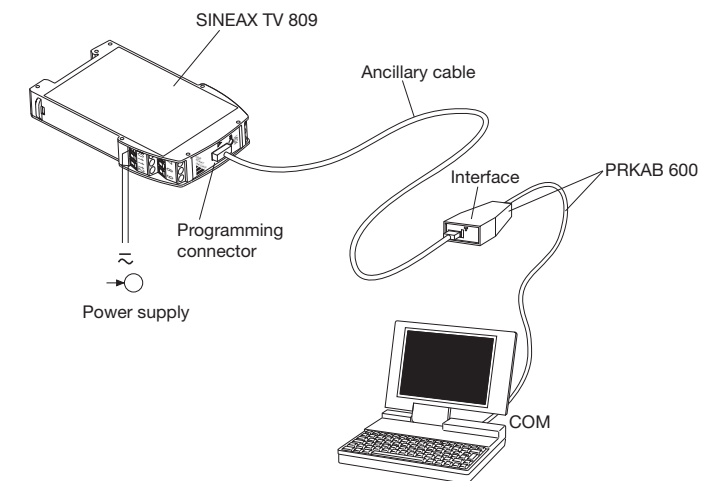

Fig. 6. Configuring a SINEAX TV 809, Ex version.

Continuation see on next page!