

# KINAX SR 709

## Transmitter for position feedback

Position transmitter with NAMUR valve fitting

CE 0102 Ex II 2 G

### Application

The position feedback transmitter KINAX SR 709 (Fig. 1 and 2) is used to measure and transmit linear displacement (stroke) on various types of control valves and other control devices. The output is a load independent DC signal. The position feedback transmitter consists of a KINAX angle transmitter and a reduction gear which converts a linear movement into an angle of rotation of 0 ... 90°. Both parts are contained in a robust cast aluminium housing. The mounting part to the control valve is based on NAMUR recommendations, (standards working group for measuring and process control in the chemical industry).

### Features / Benefits

- Measuring input: Movement, stroke

Measured variable	Measuring range limits
Movement, stroke	0 ... 10 to 0 ... 140 mm

- Setting of the measuring range is achieved via adjusting the lever system pivot point. More precise calibration is via zero and span potentiometers / Optimum adjustment of zero and span can be made to meet individual requirements
- Measuring output: DC current signal (load-independent, 2, 3 or 4-wire connection)
- Capacitive scanning system / Non-wearing
- Unit in field type housing in cast aluminium with NAMUR mounting part for fitting to control valve
- Available in type of protection «Intrinsic safety» EEx ia IIC T6 / Can be mounted within the hazardous area (see "Table 3: Data on explosion protection")

### Description

The pick-up of the stroke movement is made by means of a slotted lever. The adaption to strokes between 10 and 140 mm is made with an external lever transmission and by an internal gear ratio. The external lever transmission can be adjusted in such a way, that

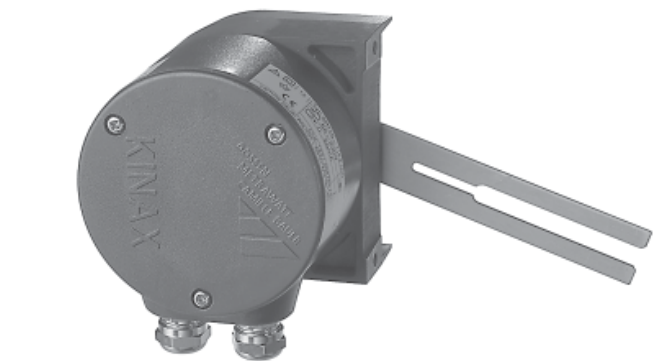

Fig. 1. Position feedback transmitter KINAX SR 709 showing the operating lever in the lower zero position, corresponding output current 0/4 mA.

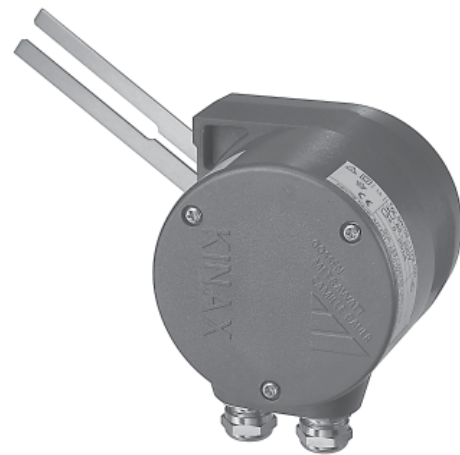

Fig. 2. Position feedback transmitter KINAX SR 709 showing the operating lever in the upper zero position, corresponding output current 0/4 mA.

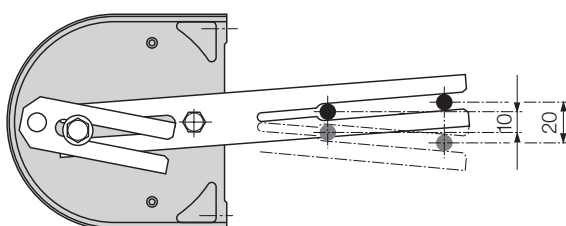

Fig. 3. Operating lever set for minimum operating angle

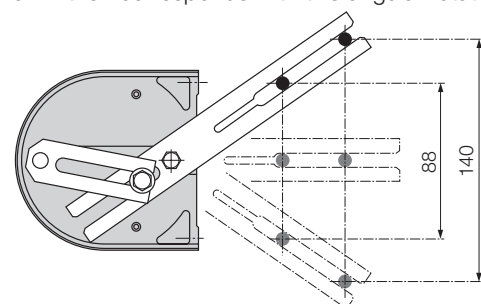

Fig. 4. Operating lever set for maximum operating angle.

# KINAX SR 709

## Transmitter for position feedback

### Technical data

#### Measuring input $\ominus$

Measured variable: Movement, stroke  
 Measuring range limits: 0 ... 10 to 0 ... 140 mm

#### Measuring output $\ominus$

Output variable  $I_A$ : Load-independent DC current, proportional to the input angle  
 Zero point correction: Approx.  $\pm 5\%$   
 Span adjustment: Approx.  $+5 / -30\%$   
 Current limitation:  $I_A$  max. 40 mA  
 Standard ranges: 0...1 mA/3 or 4-wire connection  
 0...5 mA/3 or 4-wire connection  
 0...10 mA/3 or 4-wire connection  
 4...20 mA/2-wire connection or  
 0...20 mA/3 or 4-wire connection (adjustable with potentiometer)  
 4...20 mA/3 or 4-wire connection  
 0...20 mA/4-wire connection  
 Non-standard ranges: 0...> 1.00 to 0...< 20 mA  
 3 or 4-wire connection

External resistance (load):  $R_{\text{ext}} \text{ max. } [\text{k}\Omega] = \frac{12 \text{ V}}{I_A [\text{mA}]}$   
 (for instruments with **DC/AC** power supply by AC/DC power pack, **with** electric isolation)

$R_{\text{ext}} \text{ max. } [\text{k}\Omega] = \frac{H [\text{V}] - 12 \text{ V}}{I_A [\text{mA}]}$   
 (for instruments with **DC** power supply, **without** electric isolation)  
 $I_A$  = Output signal end value

Residual ripple in output current:  $< 0.3\%$  p.p.

#### Accuracy

Linearity error:  $\leq 0.5\%$

#### Power supply H $\rightarrow \bigcirc$

DC and AC voltage: Nominal voltages and tolerances see "Table 1"

Table 1:

Nominal voltages $U_N$	Tolerances
24 ... 60 V DC/AC	DC $-15 \dots +33\%$
85 ... 230 V DC/AC	AC $\pm 15\%$

only possible with standard version, non-Ex, **with** electric isolation, with AC/DC power pack (DC and 45 ... 400 Hz)  
 Power consumption:  $< 0.9 \text{ W}$  resp.  $< 1.8 \text{ VA}$   
 Power supply effect on accuracy:  $\leq 0.1\%$  within the admissible power supply tolerance  
 DC voltage only<sup>1</sup>: 12 ... 33 V (possible with standard version, non-Ex, **without** electric isolation)  
 12 ... **30 V** (necessary with **Ex** version, type of protection "Intrinsic safety" EEx ia IIC T6, **without** electric isolation)  
 Max. residual ripple: 10% p.p.  
 Max. current consumption: Approx. 5 mA +  $I_A$   
 Power supply effect on accuracy:  $< 0.2\%$  within the admissible power supply tolerance

#### Mechanical withstand

Permissible vibration: 20 ... 200 Hz, 10 g continuous, 15 g for 2 h  
 200 ... 500 Hz, 5 g continuous, 10 g for 2 h  
 Shock:  $3 \times 50 \text{ g}$  every 10 impulses in all 3 axes  
 Mounting position: Any

#### Housing data

Material: Metal (aluminium)  
 Cable glands: 2 cable glands PG 11 in metal

<sup>1</sup> Polarity reversal protection. The voltage must not fall below 12 V.

# KINAX SR 709

## Transmitter for position feedback

There are 4 screw terminals and a grounding terminal in the rear cover for connecting the electrical leads.

The screw terminals accept gauges up to 1.5 mm<sup>2</sup> and are accessible after removing the cover.

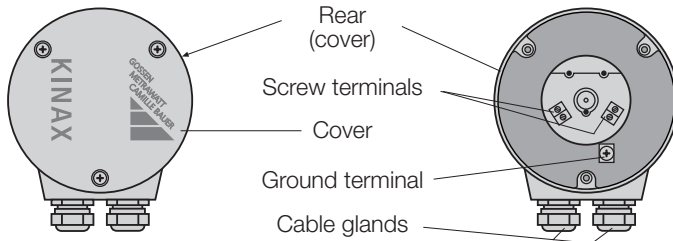

Fig. 5. KINAX SR 709 with screw terminals and cable glands.

Mounting: Directly  
or  
Fixing with NAMUR mounting part  
(see Fig. 9 and 10)

Weight: Approx. 1.1 kg

### Regulations

Electromagnetic compatibility: The standards DIN EN 50 081-2 and DIN EN 50 082-2 are observed

Intrinsically safe: Acc. to EN 50 020: 1994

Test voltage: 2.2 kV<sub>eff</sub>, 50 Hz, 1 min. between...  
... power supply and housing  
... power supply and measuring output  
(with DC/AC power supply, **with** electric isolation, with AC/DC power pack)  
500 V<sub>eff</sub>, 50 Hz, 1 min.  
all electric connections to housing  
(with DC power supply, **without** electric isolation)

Housing protection: IP 54 acc. to EN 60 529

Impulse voltage withstand: 1 kV, 1.2/50 μs, 0.5 Ws  
IEC 255-4, Cl. II

Permissible common-mode voltage: 100 V, 50 Hz

### Environmental conditions

Climatic rating:

#### Standard version

Temperature – 25 to + 70 °C  
Annual mean relative humidity ≤ 90%  
or

#### Version with improved climatic rating

Temperature – 40 to + 70 °C  
Annual mean relative humidity ≤ 95%

#### Ex version

Temperature – 40 to + 60 °C at T6  
resp. – 40 to + 75 °C at T5  
Annual mean relative humidity ≤ 95%

Altitude:

2000 m max.

Transportation and storage temperature:

– 40 to 80 °C

# KINAX SR 709

## Transmitter for position feedback

**Table 2: Specification and ordering information**

Order Code 709 –						
Features, Selection	*SCODE	no-go	1	2	6	7
<b>1. Version</b>						
1) Standard, Measuring output non intrinsically safe	A		1			
2) EEx ia IIC T6, Measuring output intrinsically safe	B		2			
6) Ex ia IIC T6, Measuring output intrinsically safe	B		6			
7) EEx ia IIC T6, Measuring output intrinsically safe	B		7			
9) Other versions on request	B		9			
<b>2. Mounting position</b>						
Lever in spring loaded position:						
0) lower end position corresp. to 0/4 mA (standard version)			0			
1) upper end position corresponding to 0/4 mA			1			
Later changes not possible.						
<b>3. Output signal (measuring output) <math>\ominus \rightarrow</math></b>						
A) 0 ... 1 mA / 3 or 4-wire connection			A			
B) 0 ... 5 mA / 3 or 4-wire connection			B			
C) 0 ... 10 mA / 3 or 4-wire connection			C			
D) 4 ... 20 mA / 2-wire connection or 0 ... 20 mA / 3 or 4-wire connection (adjustable with potentiometer)	C		D			
E) 4 ... 20 mA / 3 or 4-wire connection			E			
F) 0 ... 20 mA / 4-wire connection	D	B	F			
Z) Non-standard, 3 or 4-wire connection [mA] <span style="background-color: #cccccc; padding: 2px;"> </span> 0 ... > 1.00 to 0 ... < 20			Z			
DC/AC electrically insulated power supply only for 4-wire connection. DC non-electrically insulated power supply for (2), 3 or 4-wire connection. Only line D is possible for 2-wire connection in conjunction with power supply voltage 12 ... 33 (30) V DC! Line F: DC/AC power supply only (AC/DC power supply)						
<b>4. Power supply <math>\rightarrow \bigcirc</math></b>						
1) 24 ... 60 V DC/AC, <b>with</b> electric isolation, with AC/DC power supply	E	BC	1			
2) 85 ... 230 V DC/AC, <b>with</b> electric isolation, with AC/DC power supply	E	BC	2			
A) 12 ... 33 V DC, <b>without</b> electric isolation	F	BD	A			
B) 12 ... 30 V DC ( <b>Ex</b> ), <b>without</b> electric isolation	F	AD	B			
Lines 1 and 2: Power supply DC/AC not possible with output signal "Feature 3. line D"						

# KINAX SR 709

## Transmitter for position feedback

Order Code <b>709</b> –					
Features, Selection	*SCODE	no-go			
<b>5. Climatic rating</b>					
0) Standard climatic rating					0 . . . . .
1) Improved climatic rating at standard version, <b>without</b> electric isolation, temperature – 40 to + 70 °C, annual mean relative humidity ≤ <b>95%</b> instead of ≤ 90%		BE			1 . . . . .
2) Improved climatic rating at standard version, <b>with</b> electric isolation, with AC/DC power supply temperature – 40 to + 70 °C, annual mean relative humidity ≤ <b>95%</b> instead of ≤ 90%		BF			2 . . . . .
3) Improved climatic rating at <b>Ex</b> version, <b>without</b> electric isolation, temperature – 40 to + <b>60 °C</b> with T6 resp. – 40 to + <b>75 °C</b> with T5, annual mean relative humidity ≤ <b>95%</b> instead of ≤ 90 %		AE			3 . . . . .
<b>6. Mounting set</b>					
0) Without mounting set					. 0 . . . . .
1) With mounting set Nr. 866 288					. 1 . . . . .

\* Lines with letter(s) under “no-go” cannot be combined with preceding lines having the same letter under “SCODE”.

**Table 3: Data on explosion protection** **II 2 G**

Order Code	Type of protection “Intrinsically safe”		Certificates	Mounting location of device
	Instrument	Measuring output		
SR 709-2 with built-in KINAX 3W2 708-2	EEx ia IIC T6	$U_i = 30 \text{ V}$ $I_i = 160 \text{ mA}$ $P_i = 1 \text{ W}$ $C_i \leq 10 \text{ nF}$ $L_i = 0$	Type Examination Certificate PTB 97 ATEX 2271	<b>Within</b> the hazardous area
SR 709-6 with built-in KINAX 3W2 708-6	Ex ia IIC T6		Czech republic FTZU 98 Ex 0280	
SR 709-7 with built-in KINAX 3W2 708-7	EEx ia IIC T6		Hungary BKI Nr. Ex-98.C.535 X	

# KINAX SR 709

## Transmitter for position feedback

### Electrical connections

Non-electrically insulated 2, 3 or 4-wire connection

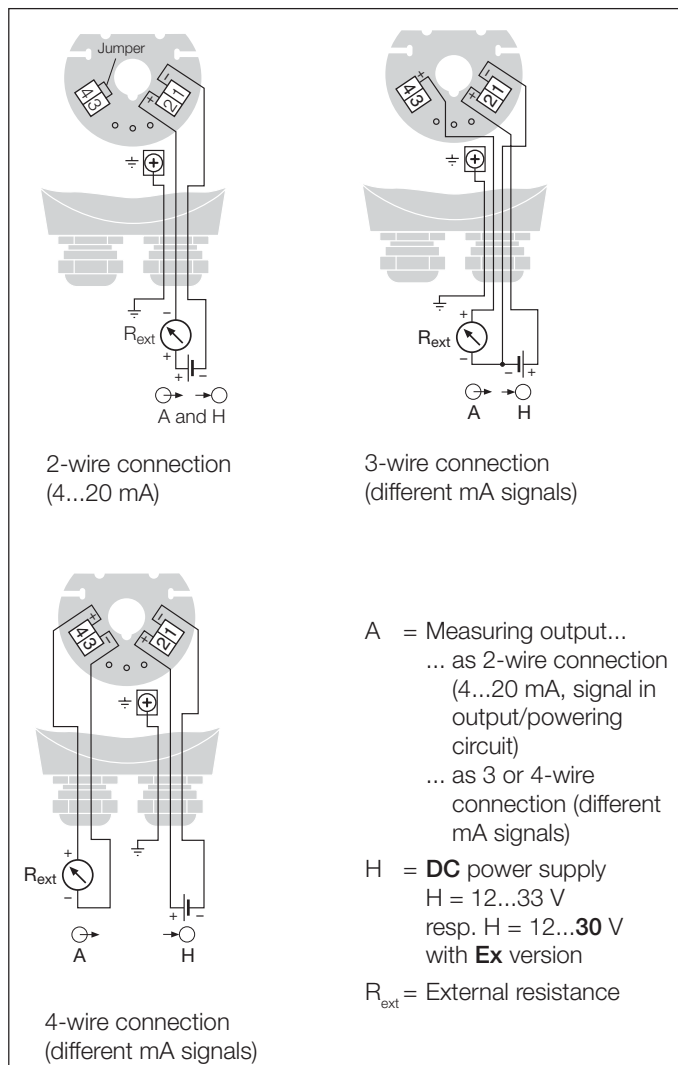

4-wire connection and electrically insulated  
AC/DC power supply

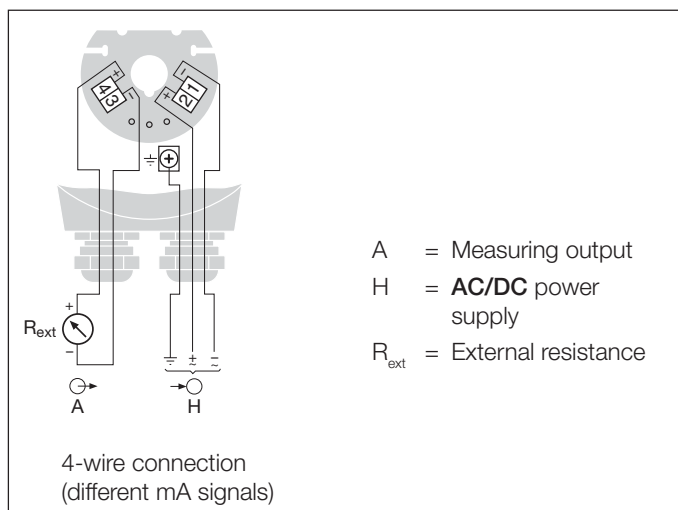

### Settings

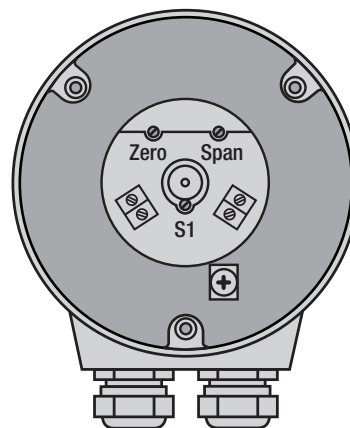

Fig. 6. Locations of the settings

ZERO = Potentiometer for zero point

SPAN = Potentiometer for full-scale measuring range

S1 = Not fitted

Transmitters with Ordering Code 709 – ..**D** (see “Table 2: Specification and ordering information”) can be used for a 2-wire connection and an output current of 4...20 mA or for 3 and 4-wire connections and an output current of 0...20 mA.

If the mode of connection is changed (see “Electrical connections”), the beginning and end of the measuring range, i.e. ZERO and SPAN, have to be recalibrated.

### Standard accessories

- 1 Operating Instructions in three languages: German, French, English
- 1 Ex approval (for instruments in Ex version only)

# KINAX SR 709

## Transmitter for position feedback

### Dimensional drawings

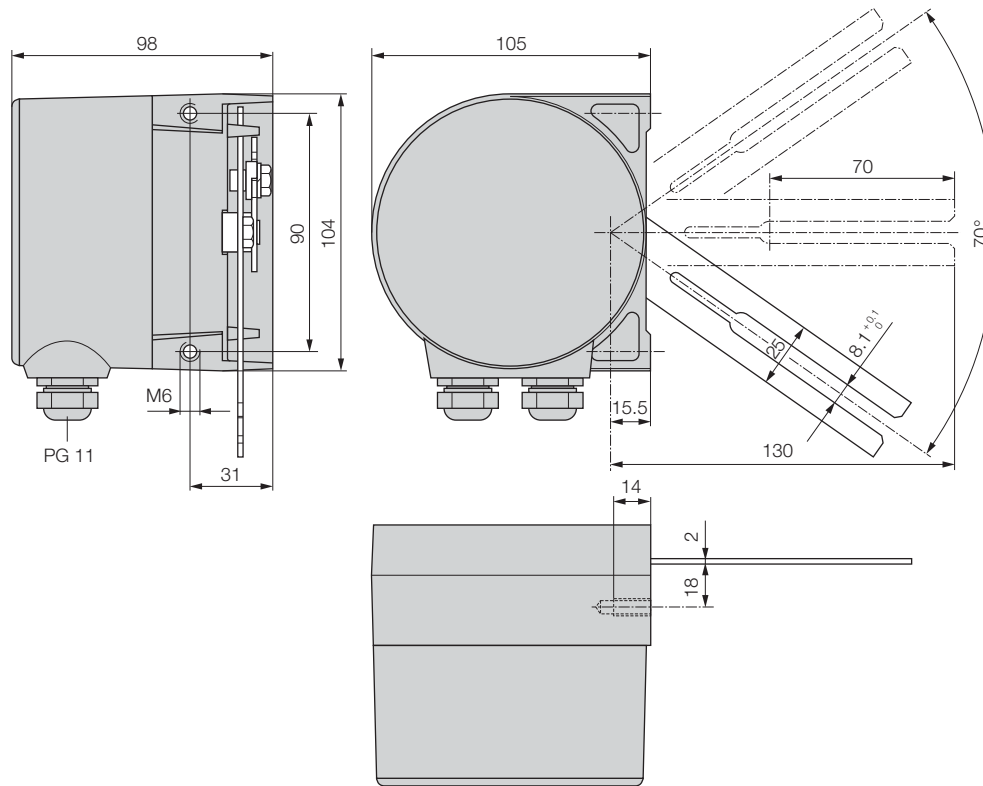

Fig. 7. Position of the KINAX SR 709 operating lever in the lower zero position, corresponding output current 0/4 mA.

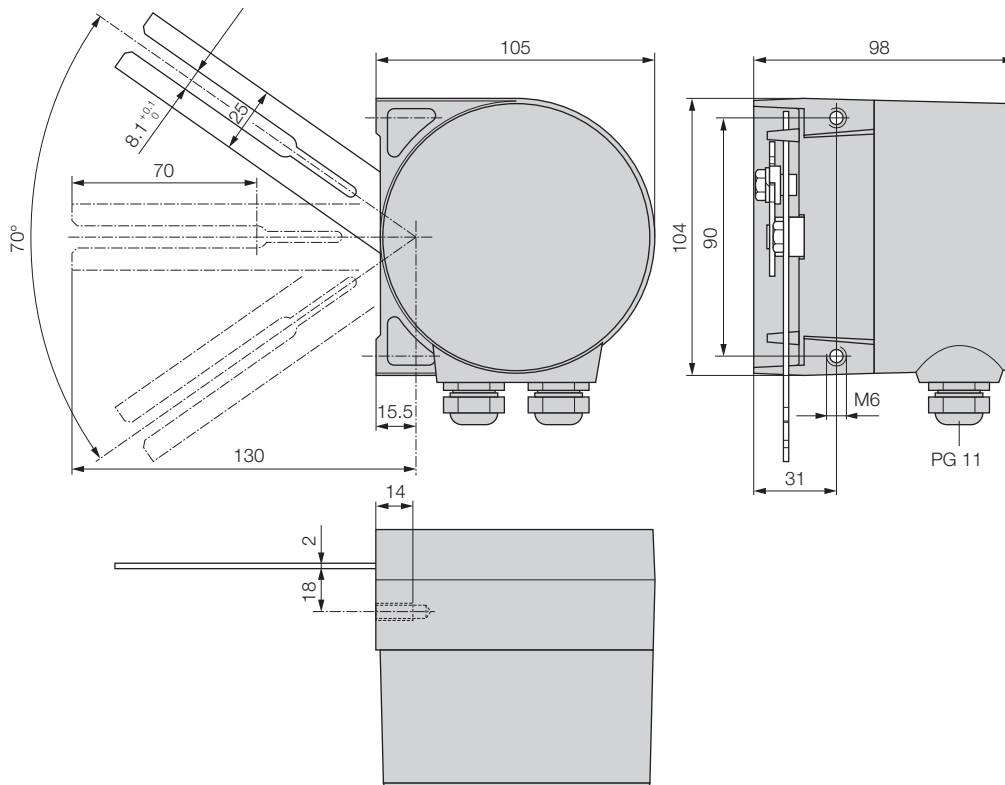

Fig. 8. Position of the KINAX SR 709 operating lever in the upper zero position, corresponding output current 0/4 mA.

# KINAX SR 709

## Transmitter for position feedback

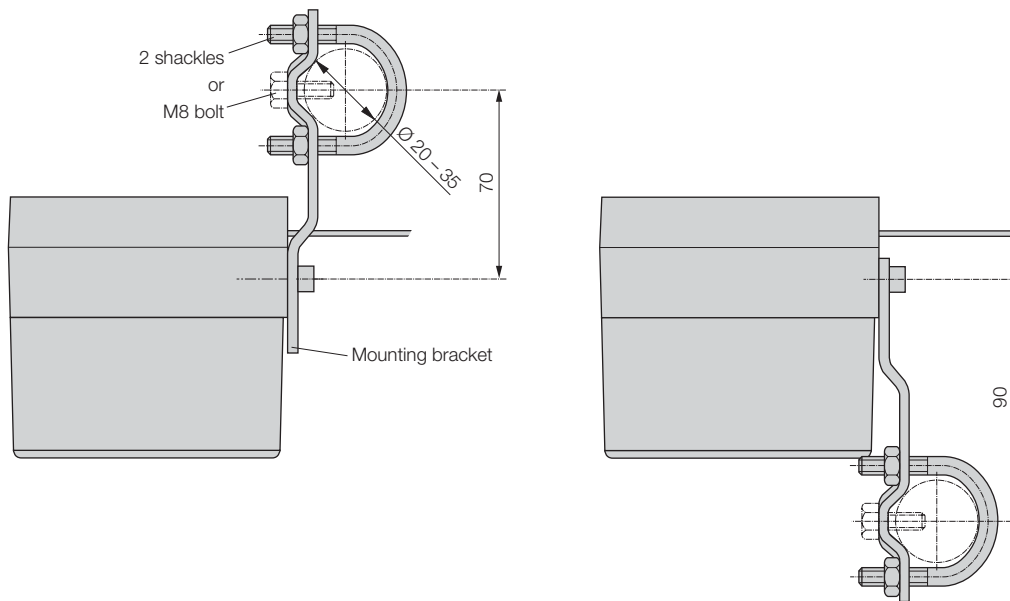

Fig. 9. KINAX SR 709 with fitting recommended by NAMUR.

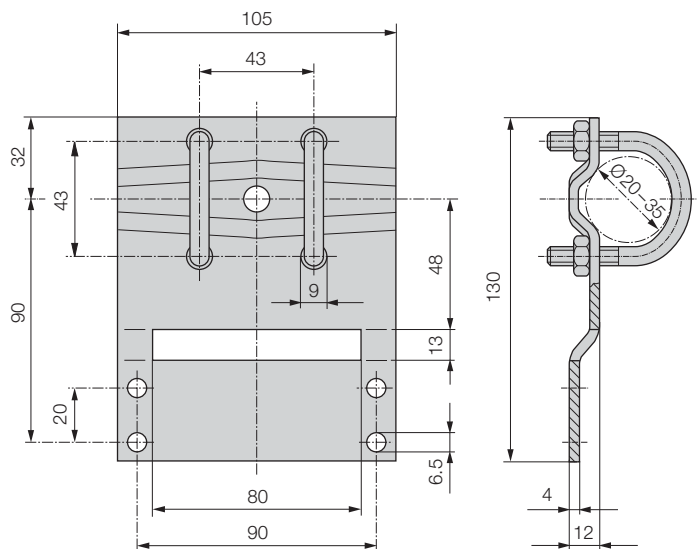

Fig. 10. NAMUR mounting set.

Subject to change without notice • Edition 07.05 • Data sheet No. SR 709 Le • A pdf version is available on the internet